

# **SOLANA BEACH SCHOOL DISTRICT**

## **BID PACKAGE NO. 2211**

**Project:** Skyline Elementary Backstop Upgrades

**Bid Deadline:** December 13, 2021. 1:00pm

**Submit Bids To:** Solana Beach School District  
Attn: Project Bidding Administrator  
309 North Rios Avenue  
Solana Beach, CA 92075

**SKYLINE BACKSTOP UPGRADES  
BID PACKAGE NO. 2211**

**TABLE OF CONTENTS**

<b><u>TABLE OF CONTENTS</u></b> .....	i
<b><u>BIDDING REQUIREMENTS</u></b>	
Notice Inviting Bids .....	NIB-1
Instructions For Bidders .....	IFB-1
Description of Work .....	DOW-1
Master Schedule .....	MS-1
Bidder Clarification Request .....	BCR-1
<b><u>REQUIRED BID FORMS</u></b> .....	
Bid Proposal .....	RBF-2
Subcontractor Listing .....	RBF-5
Bid Bond .....	RBF-7
Certification Regarding DVBE Efforts .....	RBF-9
Non-Collusion Declaration.....	RBF-11
Certification Regarding Site Visit .....	RBF-12
Certification Regarding Contractor Registration.....	RBF-13
<b><u>REQUIRED CONTRACT FORMS</u></b> .....	
Agreement for Construction Services.....	RCF-2
Certification Regarding Employee Background Checks .....	RCF-6
Certification Regarding Drug-Free Workplace .....	RCF-8
Certification Regarding Tobacco-Free Workplace.....	RCF-9
Certification Regarding Workers Compensation.....	RCF-10
Notice and Certification Regarding Lead-Free Materials.....	RCF-11
Certification Regarding Asbestos .....	RCF-13
Payment Bond .....	RCF-14
Performance Bond.....	RCF-17
Certification Regarding DVBE Participation .....	RCF-21
<b><u>PROVISIONS OF THE CONTRACT</u></b>	
Special Provisions .....	SP-1
General Provisions.....	GP-1



## NOTICE INVITING BIDS

**NOTICE IS HEREBY GIVEN** that the Solana Beach School District (“District”) is seeking sealed bids from qualified construction contractors for construction of the following public-works project (“Project”): Skyline Backstop Upgrades: 2211

**PLACE FOR SUBMITTING BIDS:** Bids must be submitted to the District at the following location (“Place for Submitting Bids”):

Solana Beach School District  
Attn: Project Bidding Administrator  
309 North Rios Avenue  
Solana Beach, CA 92075

**BID DEADLINE:** Bids must be received at the Place for Submitting Bids not later than **1:00pm on December 10, 2021.**

**BID DOCUMENTS:** The Bid Documents also may be downloaded, at no cost, from the following link on the District’s website: [SBSD.net](http://SBSD.net).

**REQUIRED BID SECURITY:** Each bid must be submitted with bid security as described in the Instructions For Bidders.

**CONTRACTOR LICENSE:** The class or classes of California contractor licenses required to bid on and perform the Work are: C-13, B.

**PRE-BID CONFERENCE:** The District will conduct a mandatory pre-bid conference and site visit at **Skyline School, 8:00am on December 7, 2021, at 8:00AM.** The conference initially will commence at **606 Lomas Santa Fe Ca. 92075.** Attendance at the pre-bid conference and site visit is mandatory, and any bidder that does not attend shall be deemed non-responsive.

**AWARD OF CONTRACT:** The award of the Contract will be based on the following method of determining the lowest bid.

**SURETY BONDS:** As described in the General Provisions, the successful bidder must provide a Performance Bond and a separate Payment Bond, each in an amount equal to 100% of the total Contract Price, and each issued by a California-admitted surety as defined in Code of Civil Procedure Section 995.120.

**LABOR LAW:** The Project is a “public work” project that is subject to, among other laws, Labor Code Sections 1720 through 1861, inclusive. As described in the Instructions For Bidders, each contractor (including subcontractors) must be registered with the California Department of Industrial Relations (“DIR”) in accordance with Labor Code Section 1725.5, and bidders must provide evidence of registration for themselves and their subcontractors. Each worker on the Project must be paid not less than the applicable prevailing rates of per-diem wages in the locality in which the Work is to be performed for each craft or type of worker needed to execute the Contract (“Prevailing Wages”). A copy of the applicable rates of Prevailing Wages is on file and available for review at the Place for Submitting Bids, and a copy will be posted at the Project Site. The Project is subject to compliance monitoring and

enforcement by the DIR. The successful bidder will be required to post all job-site notices required by DIR regulations and other applicable law. If so specified in the Special Provisions, the District will conduct a mandatory conference for the purpose of describing labor-law requirements.

**RETENTION:** Substitution of securities in lieu of Retention, pursuant to Public Contract Code Section 22300, will be permitted as provided in the General Provisions. As described in the Special Provisions, the District will withhold Retention in excess of five percent of each payment because the Project is substantially complex.

**PUBLICATION DATES:** November 29, 2021; December 6, 2021.

## INSTRUCTIONS FOR BIDDERS

**Caution:** Read these Instructions For Bidders and other Bid Documents carefully. Do not assume that the documents are the same as similar documents you previously may have obtained from the District.

**1. Architect.** The architect of record, if any, for the Project (“Architect”) is identified in the Special Provisions. The Architect may have prepared and/or approved graphic and pictorial illustrations in connection with the Project that show the design, location, and scope of certain portions of the Work and the Project, generally including plans, elevations, sections, details, schedules, and diagrams (“Plans”). The Architect also may have prepared and/or approved written requirements for materials, equipment, construction systems, quality, workmanship, services and other things to be furnished in connection with the Work and the Project (“Specifications”). If there is no Architect for the Project, the District may delegate to its staff and/or consultants any or all of the responsibilities specified in the Bid Documents as being the responsibility of the Architect.

**2. Construction Manager.** Notwithstanding that the District may intend to complete the Project using a single general contractor, the District may contract for the services of a construction manager or other consultant in connection with the Project (“Construction Manager”). If the District has contracted with a Construction Manager prior to issuance of the Bid Documents, the Construction Manager is identified in the Special Provisions. The Construction Manager will be the District’s representative during the bidding, construction and close-out of the Work and will assist the District in the administration of the Contract.

**3. Requirements for Pre-Bid Conference and Site Visit.** Prospective bidders in attendance at the pre-bid conference and site visit (regardless of whether conference/site visit is mandatory or optional) must be dressed appropriately and with safety in mind, including, at a minimum, by wearing: (i) closed-toe, closed-heel, and regular-heel shoes (such as tennis shoes or work boots); (ii) long pants; and (iii) a shirt with sleeves. Shorts, dresses, sleeveless shirts, and open shoes will not be permitted on the Project Site. Regardless of whether the pre-bid conference initially commences at the District’s main offices or at the Project Site, prospective bidders must not enter the Project Site unless and until a District representative is present and directs them to do so. Prospective bidders are responsible for their own transportation. NO CONFERENCES OR SITE VISITS WILL BE ARRANGED FOR BIDDERS THAT FAIL TO ATTEND THE SCHEDULED CONFERENCE AND SITE VISIT. PROSPECTIVE BIDDERS MUST NOT VISIT THE PROJECT SITE AT ANY TIME OTHER THAN THE DATE AND TIME FOR THE PRE-BID CONFERENCE AND SITE VISIT SET FORTH IN THE NOTICE INVITING BIDS.

**4. Examination of Project Site and Contract Documents.** During the pre-bid conference and site visit (regardless of whether conference/site visit is mandatory or optional), each bidder must inspect the Project Site and become fully acquainted with the conditions in and under which the Work will be performed, so that the bidder fully understands the facilities, difficulties, restrictions and requirements attendant to the performance of the Work on and at the Project Site. If so provided in the Special Provisions, each bidder must complete, execute and submit to the District the “Certification Regarding Site Visit” form included in the Required Bid Forms. In addition, each bidder must thoroughly examine and develop an understanding of all of the Contract Documents, including, without limitation, the Plans, Specifications, Agreement for Construction Services, General Provisions, Special Provisions, and required forms. Note that any capitalized term used, but not defined, in any particular Bid Document or Contract Document shall have the defined meaning in another of the Bid Documents or

Contract Documents. The failure of a bidder to understand the conditions in and under which the Work is to be performed, or to examine and understand any of the Contract Documents, shall not relieve the bidder from any obligations pursuant to its bid or the Contract Documents.

**5. Project is a Public Work.** Except as otherwise provided or permitted by law, the Project is a “public work” and “public project” within the meaning of various provisions of the Public Contract Code, Labor Code, Civil Code, and other applicable legal requirements. Therefore, the performance of the Work shall be subject to such requirements. The Contract Documents include various provisions relating to public works and public projects as provided by law, and each bidder must thoroughly review and become familiar with the Contract Documents as described above in these Instructions For Bidders. However, the Contract Documents do not include comprehensive statements of all requirements of law applicable to public works and public projects, and each bidder shall be deemed and construed to have acknowledged that fact by submitting a bid for the Work. In addition, by submitting a bid for the Work, each bidder shall be deemed and construed to represent and warrant that it is familiar and knowledgeable with respect to all requirements of law applicable to public works and public projects generally and to the Work specifically.

**6. Requests for Clarification of Bid Documents.** If a prospective bidder is in doubt as to the true meaning of any part of the Contract Documents, or finds any conflict, omission or other discrepancy in any Plans, Specifications or other Contract Documents, the bidder must submit a written request, using the “Bidder Clarification Request” form included in the Bid Documents, for an interpretation or correction of the Contract Documents in question. Bidder Clarification Requests must be submitted to the District not later than the “Bidder Clarification Request Deadline” specified in the Master Schedule. The District will attempt to, but does not guarantee that it will, respond to each Bidder Clarification Request that is submitted by the Bidder Request Clarification Deadline. A response to a Bidder Clarification Request may be in the form of a clarification indicated on the applicable Bidder Clarification Request or an addendum to the Contract Documents, but each response will in any case be provided to all prospective bidders known to have obtained a copy of the Bid Documents from the District.

**7. Modification of Bid Documents.** Prior to the opening of bids, the Architect will issue interpretations or corrections of the Bid Documents only by addendum or addenda to the Contract Documents. A copy of each addendum will be mailed or otherwise delivered to each prospective bidder that has obtained a copy of the Bid Documents by paying a deposit. Other prospective bidders shall be responsible for checking the District’s website to determine whether any such addenda have been issued. Any bidder that fails to acknowledge receipt of each and all addenda in its Bid Proposal shall be deemed non-responsive.

**8. Listing of Subcontractors.** In accordance with the Subletting and Subcontracting Fair Practices Act (Public Contract Code Section 4100 *et seq.*), each bidder must submit with its bid the names and locations of the places of business of each subcontractor that will perform any portion of the Work, or that, under subcontract to the bidder, will specially fabricate and install a portion of the Work, in an amount in excess of one-half of one percent of the total amount of the bidder’s bid. A bidder may not list more than one subcontractor for any one portion of the Work. A bidder that fails to list a subcontractor for any portion of the Work represents that it is fully qualified to, and agrees that it shall, perform such Work using its own forces. If the Bid Documents require the bidder to submit alternate bids and the bidder intends to use different or additional subcontractors for any of the alternates, the bidder must submit a separate, complete list of subcontractors for each such alternate. The lists of

subcontractors must be set forth on the “Subcontractor Listing” form that is included in the Required Bid Forms.

**9. Registration With DIR.** No contractor may submit a bid for any work on a public works project unless the contractor is, and no subcontractor may be listed in any bid for work on a public works project unless the subcontractor is, currently registered with the California Department of Industrial Relations (“DIR”) and qualified to perform public work pursuant to Labor Code Section 1725.5. In addition, no contractor or subcontractor may be awarded a contract for work on a public works project, or may perform any work on a public works project, unless the contractor or subcontractor is currently registered with the DIR and qualified to perform public work pursuant to Labor Code Section 1725.5. It is not a violation of Labor Code Section 1725.5 for an unregistered contractor to submit a bid authorized by Business and Professions Code Section 7029.1 or Public Contract Code Section 20103.5, if the contractor is registered at the time the contract is awarded. Each bidder must complete, execute, and submit with its bid the “Certification Regarding Contractor Registration” form included in the Required Bidding Forms. See Section 11.10 of the General Provisions for additional information regarding registration with the DIR.

**10. DVBE Efforts.** BIDDERS MUST COMPLY WITH THE REQUIREMENTS OF THIS SECTION ONLY IF THE SPECIAL PROVISIONS REQUIRE SUCH COMPLIANCE. The District has adopted a goal for DVBE participation in the Project by Disabled Veteran Business Enterprises (“DVBE”) of three percent of the overall amount expended for certain new-construction and modernization projects each year. Each bidder must make and document its reasonable efforts to obtain DVBE participation in connection with the Work. In order to be considered reasonable efforts, a bidder’s efforts should include advertising in appropriate publications and contacting any responding DVBE. Alternatively, if so provided in the Special Provisions, the District will advertise for DVBE contractors for the Work, and bidders must contact the District to obtain information regarding any responding DVBE contractors. The bidder also should contact any DVBE contractors that the bidder knows and that could perform a portion of the Work or otherwise participate in the Contract. Each bidder must complete, execute and submit with its bid the “Certification Regarding DVBE Efforts” form included in the Required Bid Forms, and the District may reject as non-responsive any bid that does not comply with such requirement.

**11. Substitution of Specified Items.**

**11.1 Requests for Substitution.** Except as may be provided in the Special Provisions with respect to Sole Source Items, the requirement for any material, equipment, process, item or other thing specified in the Bid Documents (each a “Specified Item”) shall be interpreted as if followed by the words “or equal,” and a bidder may offer in place of a Specified Item any material, product, service, or other thing that the bidder can demonstrate is, in every respect, materially equal to or better than the Specified Item and that will completely accomplish the intended aesthetics, purposes and/or functions of the Specified Item. Each substitution request is subject to and must conform with the requirements of the General Provisions, including, without limitation, requirements for submitting documentation in support of the request.

**11.2 Timing for Submission of Requests for Substitution.** A SUBSTITUTION REQUEST MUST BE SUBMITTED TO THE DISTRICT NOT LATER THAN SEVEN DAYS PRIOR TO THE BID DEADLINE SPECIFIED IN THE NOTICE INVITING BIDS. The District will not consider any substitution request received thereafter, except to the extent provided in the General Provisions. Concurrently with submitting a substitution request, the bidder must provide all information required pursuant to the General Provisions to substantiate the request.

**11.3 Approval of Requests for Substitution.** The bidder shall be responsible for establishing that a proposed substitution of a Specified Item satisfies all requirements of the Contract Documents, including, without limitation, that the proposed substitute item is, in every respect, materially equal to or better than the Specified Item. The District may at any time request that a bidder provide any additional information regarding a substitute item that the bidder has proposed. The District, in consultation with the Architect, will decide whether to approve a substitution based on the information provided by the bidder and, in the District's sole discretion, on information obtained by the District from other sources. The District has the sole discretion to determine whether a proposed substitute item is equal to or better than a Specified Item. Any request for substitution that is granted by the District shall be documented and processed by means of a Change Order after execution of the Contract. The District may condition its approval of any substitution upon delivery to the District of an extended warranty or other assurances of adequate performance of the substitute item. The District shall not be required to make a determination in regard to any substitution request and/or substantiating information prior to award of the Contract. If the District gives a Notice of Award to the successful bidder for the Contract, but subsequently disapproves a substitution proposed by the bidder, the bidder must provide the Specified Item in accordance with the Contract Documents and at no additional cost to the District.

**11.4 Costs and Delays Arising from Substitution.** The successful bidder for the Contract, if it has requested any substitutions of Specified Items, shall be responsible for and shall bear any and all risks, expenses and costs of delay arising from required review or approval of the substitutions by the California Department of General Services, Division of State Architect ("DSA") and/or other governmental agency with competent jurisdiction.

**12. Use of Bid Proposal Form is Mandatory.** Each bid must be submitted on the "Bid Proposal" form included in the Required Bid Forms. Unless expressly permitted by the Bid Documents, a bidder must not: (i) make any changes, additions or other modifications to the Bid Proposal form or other documents to be submitted with the Bid Proposal; (ii) restate or recharacterize the Work in the bid; or (iii) make any alternative proposals not permitted by the Bid Documents. The District may reject as non-responsive any bid that does not strictly comply with the foregoing.

**13. Preparing the Bid.** Bidders must fully and properly complete all information required to be included on the Bid Proposal form. A bid may contain an erasure, interlineation, or other correction only if the correction is made to the information entered by the bidder (not to the pre-printed text of the Bid Proposal form), does not result in any inconsistency or ambiguity, and is authenticated by affixing, in the margin immediately adjacent to the correction, the initials of the person or persons signing the bid. In the event of inconsistency between words and numbers, words shall govern over numbers and, for purposes of the bid, the District may rely on the words.

**14. Bid Security.** Each bid must be submitted with security in an amount equal to ten percent of the bidder's Total Bid Amount. For purposes of the Bid Documents, "Total Bid Amount" shall mean the total of a bidder's base bid plus all additive alternates. In the event a bidder's bid security does not equal at least ten percent of the Total Bid Amount, the District may reject that bid as non-responsive. The bid security must be in one of the following forms: (i) a cashier's or certified check payable to the District; or (ii) a bid bond. Personal and business checks are not acceptable as bid security. If the bidder desires to submit bid security in the form of a bid bond, it must be an executed copy of the "Bid Bond" form included as one of the Required Bid Forms (without any interlineations or

other modifications) and must be issued by a California-admitted surety as defined in Code of Civil Procedure Section 995.120. Unless forfeited, the District will return security to the bidders within a reasonable time, but not later than sixty days after award of the Contract for the Work.

**15. Non-Collusion Declaration.** Each bidder must complete, execute and submit to the District, with its bid, a copy of the “Non-Collusion Declaration” form included in the Required Bid Forms.

**16. Signing the Bid and Other Required Documents.** The Bid Proposal form and other Required Bid Forms, the Bid Bond, and all other documents to be submitted with the bid that require an original signature of the bidder must be signed in permanent ink, preferably blue in color, by a person or persons duly authorized to sign documents and contractually bind the bidder in connection with the Work. The District may reject as non-responsive any Bid Proposal form containing a stamped or mechanically printed signature.

**17. Sealing and Labeling the Bid.** The completed Bid Proposal form, other Required Bid Forms, and all additional documents and other materials to be submitted with the bid must be enclosed in a sealed envelope. No information must be apparent on the outside of the bid envelope other than the name/number of the Project, the Bid Deadline and the company name and address of the bidder, and the District may reject any bid if the outside of the bid envelope has additional information or identifying marks.

**18. Extensions to Bid Deadline.** For purposes of the Notice Inviting Bids and these Instructions For Bidders, any reference to the “Bid Deadline” shall mean the date and time specified as the Bid Deadline in the Notice Inviting Bids and any authorized extension(s) thereto. The Bid Deadline shall be extended by no less than seventy-two hours if the District issues any material changes, additions, or deletions to the Bid Documents within seventy-two hours of the Bid Deadline.

**19. District Receipt of Bids.** The District must receive any and all bids prior to the Bid Deadline and at the Place for Submitting Bids described in the Notice Inviting Bids. The clock, computer or other device located at the Place for Submitting Bids and designated as the official bid clock shall be used in determining whether bids have been timely received by the District, regardless of whether the time shown on the official bid clock is precisely accurate. Each bidder is solely responsible for ensuring that its bid is timely received by the District. A bidder must submit its bid to the District via personal or other delivery. The District will not accept any oral bid or bid sent via facsimile or electronic transmission. At no time will District telephones or facsimile machines be available for use by bidders. Each bid received by the District after the Bid Deadline will be returned to the bidder unopened.

**20. Modifying or Superseding a Bid.** Not later than the Bid Deadline, a bidder may modify or supersede its original bid by withdrawing its original bid as provided in these Instructions For Bidders and concurrently submitting a replacement bid for the Work in accordance with the Bid Documents. The District shall reject any replacement bid that is not received by the District prior to the Bid Deadline. The late receipt and rejection of a bidder’s replacement bid shall not be deemed or construed to constitute a withdrawal of the original bid by the bidder, and the District still may accept the original bid if responsive and the bidder is a responsible contractor. Each replacement bid received by the District after the Bid Deadline will be returned to the bidder unopened.

**21. Withdrawing a Bid.** A bidder may withdraw its bid at any time prior to the Bid Deadline by submitting a written request to the District via personal or other delivery. The District will not accept

any oral withdrawal request or any withdrawal request sent via facsimile or electronic transmission. A withdrawal request must be signed by an authorized representative of the bidder. A withdrawal request received by the District after the Bid Deadline shall in no event be deemed or construed to constitute a withdrawal of the bid, and the District still may accept the bid if it is responsive and the bidder is a responsible contractor. After receipt of a timely withdrawal request, the District shall return the bidder's bid security upon request. Except as provided in Public Contract Code Section 5100 *et seq.*, if a bidder has not withdrawn its bid prior to the Bid Deadline, the bidder thereafter may not withdraw its bid for a period of sixty days after the Bid Deadline.

**22. Bid Irregularities.** The District, in accordance with applicable law, may waive any minor irregularity or informality in any bid or in the bidding process. The District may, but is not required to, seek information from any bidder that might resolve an ambiguity in the bidder's bid.

**23. Bid Protests.** Any bidder that has duly submitted a bid for the Work may protest the process used to seek bids for the Work, another bid for the Work and/or the intended award of the Contract for the Work only by filing a written protest with the District in accordance with the procedures set forth in this Section (each a "Bid Protest"). The District will not accept or consider any oral Bid Protest (e.g., by telephone) or any Bid Protest sent via electronic transmission (e.g., email). In order for a Bid Protest to be valid and be considered by the District, the Bid Protest:

- (i) Must be received by the District not later than 4:00 p.m. on the fifth business day following the opening of bids;
- (ii) Must clearly identify the bidder that is filing the Bid Protest, together with the name, address and telephone number of the person representing the bidder for purposes of the Bid Protest;
- (iii) Must clearly identify the specific bid, bidding process, or other matter that is the subject of the Bid Protest;
- (iv) Must clearly identify the specific provisions of all documents relevant to the Bid Protest;
- (v) Must clearly identify and describe in detail the specific basis or bases for the Bid Protest and all facts relevant thereto;
- (vi) Must clearly identify and describe in detail all arguments by the protesting bidder in support of the Bid Protest, including, without limitation, citations to applicable statutory requirements; and
- (vii) Must be submitted with all documentation the protesting bidder desires to submit that is relevant to and supports the basis or bases underlying the Bid Protest.

If a Bid Protest does not comply with each and all of the foregoing requirements (provided that a protesting bidder will be deemed to have submitted all documentation that it desires in accordance with clause (vii) of the foregoing), the District will reject the Bid Protest as invalid. However, upon receipt of a valid Bid Protest, the District and/or its legal counsel will review the Bid Protest and provide a written response to the protesting bidder setting forth a recommendation for action by the Board of Education of the Solana Beach School District ("District Board") in response to the Bid Protest. Action on a Bid Protest by the District Board shall be a condition precedent to the filing of any claim or



demand and to the initiation of any action (legal or equitable) or other proceeding arising from the matter(s) protested.

CAUTION: COMPLIANCE WITH THE FOREGOING BID PROTEST REQUIREMENTS IS MANDATORY. EACH BIDDER THAT DESIRES TO PROTEST MUST FILE ITS OWN BID PROTEST IN ACCORDANCE WITH THE FOREGOING REQUIREMENTS, AND NO BIDDER MAY RELY ON A BID PROTEST BY ANOTHER BIDDER AS A MEANS OF SATISFYING SUCH REQUIREMENTS. COMPLIANCE WITH THE FOREGOING REQUIREMENTS IS THE SOLE AND EXCLUSIVE MEANS OF PROTESTING A BID, THE BIDDING PROCESS AND/OR THE INTENDED AWARD OF THE CONTRACT, AND FAILURE TO SO COMPLY SHALL BE DEEMED AND CONSTRUED AS A WAIVER OF ANY AND ALL RIGHTS THE BIDDER MAY HAVE TO PURSUE A CLAIM, DEMAND, OR ACTION ARISING FROM ANY SUCH MATTER.

**24. District Award of Contract.** The District Board in its sole discretion may reject all bids. If the District Board awards the Contract, the award will be to the responsible bidder with the lowest responsive bid from among all responsible and responsive bidders (“Successful Bidder”). If two or more responsive and responsible bidders have submitted the same low bid, the District shall determine the Successful Bidder by means of a coin toss or some other random method. The District will issue notice of the award of the Contract to the Successful Bidder (“Notice of Award”).

**25. Bidder Execution of Contract.** The Successful Bidder shall have seven calendar days after the date of the Notice of Award to execute the Contract and deliver it to the District with all other documents required in accordance with the Contract Documents. If the Successful Bidder fails to execute and provide all such documents within that seven-day period: (i) the Successful Bidder shall forfeit the bid security submitted with its bid; and (ii) the District may award the Contract to one of the other responsible and responsive bidders or release all bidders.

**26. Time for Completion of Work and Liquidated Damages.** The Successful Bidder must complete the Work in accordance with the Contract Documents and within the time period specified in the Master Schedule, as such time period may be adjusted in accordance with the Contract Documents. The failure of the Successful Bidder to fully complete the Work within such time period(s) may result in the District assessing Liquidated Damages as provided in the General Provisions.

**27. Subcontractor Eligibility and Licensing.** The Successful Bidder shall in no event permit a subcontractor to perform any of the Work if that subcontractor is ineligible to work on a public work or public project. Each subcontractor that the Successful Bidder intends shall perform any portion of the Work must be licensed in accordance with law by the Contractors State License Board prior to commencing its portion of the Work.

**28. Prevailing Wages and Labor-Law Compliance Monitoring.** The Successful Bidder and each of its subcontractors (regardless of tier) shall pay not less than the applicable Prevailing Wages for each craft or type of worker needed to execute the Contract. A copy of the per-diem rates of Prevailing Wages applicable to the Work is on file with the District and is available for review at the location specified in the Notice Inviting Bids as the Place for Submitting Bids, and a copy will be posted at the Project Site. The Work will be subject to monitoring by the DIR as to compliance with labor-law requirements, as described in more detail in the General Provisions.

**29. Fingerprinting and Employee Background Checks.** If so specified in the Special Provisions, the Successful Bidder, prior to entering in or upon the Project Site for purposes of

commencing the Work, must comply with the requirements for employee background checks set forth in Section 3.7 of the General Provisions. The District reserves the right to subsequently alter such determination in appropriate circumstances, including, without limitation, in any case that the time for performance of the Work has been or will be extended beyond the time specified in the Master Schedule. The District may impose other requirements designed to protect students regardless of whether it requires such employee background checks. The Successful Bidder shall be responsible for compliance with any and all such requirements with respect to its own employees and the employees of its subcontractors.

**30. Discrimination Prohibited.** In connection with performance of the Work, neither the Successful Bidder nor any of its subcontractors of any tier shall illegally discriminate against any prospective or existing employee in violation of applicable law. The Successful Bidder must comply with applicable federal and California laws prohibiting such discrimination and must require like compliance by any and all subcontractors performing any of the Work.

## DESCRIPTION OF WORK

- A. The Work consists of any and all labor, materials, goods, supplies, equipment, tools, utilities, temporary facilities, transportation, delivery services, and other services and things of any nature whatsoever as are expressly and impliedly necessary to timely and satisfactorily complete the Project: (i) in strict accordance with the Contract Documents; and (ii) not later than the Required Completion Date specified in the Master Schedule. The Work consists generally of the following: Addition of fence posts and netting as described in the attached engineered plans/drawings. The fence material should match existing color. The fencing contractor will be required to coordinate the installation with the District's staff. Work to commence on February 19, 2022, and will be completed on February 27, 2022.
  
- B. The Project Site: Skyline School 606 Lomas Santa Fe Drive, Solana Beach, CA 92075. Baseball Field.

## MASTER SCHEDULE

**District:** Solana Beach School District

**Project:** Skyline Backstop Upgrades

**Bid Package No.:** 2211

---

Some or all of the dates and times set forth in this Master Schedule are anticipated dates and times as of the date the District issued the Notice Inviting Bids for the Project and are subject to change prior to award of the Contract. The Contractor must coordinate the schedule for completion of the Work with the District to ensure that the Work will not unreasonably interfere with District operations, and, to that end, the District may require that Contractor perform the Work during non-school hours, on weekends and/or during school holidays and other breaks; provided that the District and the Contractor shall endeavor to schedule reasonable blocks of time for performance of the Work as will be cost-efficient for the Contractor.

	<u>DATE</u>	<u>TIME</u>
Advertisement	November 29, 2021 December 6, 2021	N/A
Bid Documents Available	November 29, 2021	N/A
Pre-Bid Conference	December 7, 2021	Skyline School, 8:00am
Bidder Clarification Request Deadline	December 8, 2021	8:00am
Deadline for Final Addendum	December 9, 2021	10:00am
Bid Opening	December 13, 2021	1:00pm
Award of Contract	December 13, 2021	N/A
Notice of Award	January 21, 2022	N/A
Last Day for District to File DIR Form PWC-100	February 7, 2022	N/A
Notice to Proceed	January 21, 2022	N/A
Preconstruction Meeting	February 14, 2022	Skyline School
Work to Commence*	February 19, 2022	N/A
Required Completion Date	February 27, 2022	Skyline School

\*Not less than seven days following the date of the Notice of Award

# BIDDER CLARIFICATION REQUEST

**District:** Solana Beach School District

**Project:** Skyline Backstop Upgrades

**Bid Package No.:** 2211

**Bidder Submitting Request:** \_\_\_\_\_

Identify issue (including, as applicable, drawing/specification number): \_\_\_\_\_  
\_\_\_\_\_  
\_\_\_\_\_

Clarification requested: \_\_\_\_\_  
\_\_\_\_\_  
\_\_\_\_\_

Print Name: \_\_\_\_\_ Signature: \_\_\_\_\_ Date: \_\_\_\_\_

*(Note: Architect and/or District to complete the portion of this form below.)*

Date Request Received: \_\_\_\_\_ Response No.: \_\_\_\_\_

Response to request for clarification: \_\_\_\_\_  
\_\_\_\_\_  
\_\_\_\_\_  
\_\_\_\_\_  
\_\_\_\_\_

Clarification issued by:

Architect:  
\_\_\_\_\_  
Name  
\_\_\_\_\_  
Signature  
\_\_\_\_\_  
Date

District:  
\_\_\_\_\_  
Name  
\_\_\_\_\_  
Signature  
\_\_\_\_\_  
Date

## REQUIRED BID FORMS

The District shall deem to be non-responsive each bidder that fails to complete, duly execute and submit the following forms with its bid:

1. Bid Proposal
2. Subcontractor Listing
3. Bid Bond
4. Certification Regarding DVBE Efforts
5. Non-Collusion Declaration
6. Certification Regarding Site Visit
7. Certification Regarding Contractor Registration

# BID PROPOSAL

(Do not leave any information blank)

**District:** Solana Beach School District

**Project:** Skyline Backstop Upgrades

**Bid Package No.:** 2211

**Bidding Contractor ("Bidder"):** \_\_\_\_\_

The undersigned hereby certifies to the District, subject to penalty for perjury pursuant to the laws of the State of California, that all of the following is true and correct:

- A. The undersigned is a duly authorized representative of the Bidder and, in that capacity, has reviewed the information set forth in this Bid Proposal form and the Bid Documents, and has executed and submitted this Bid Proposal on behalf of the Bidder.
- B. The Bidder is duly licensed as a contractor by the Contractors State License Board of the State of California ("CSLB"), such license is in full force and effect as of the date the Bidder has submitted this bid to the District, and the classification(s) of such license is appropriate to allow the Bidder to perform all of the Work in accordance with California law. The number classification(s) of the license issued to the Bidder by the CSLB are:

License # \_\_\_\_\_;

Class(es): \_\_\_\_\_.

- C. The Bidder has become familiar with the Project Site as certified in the Certification Regarding Site Visit submitted concurrently herewith, has become familiar with the Contract Documents, and hereby represents and warrants that it is sufficiently experienced and qualified, and that it has sufficient financial and other resources, to perform and complete the Work in strict accordance with the Contract Documents.
- D. Being sufficiently experienced and qualified to perform the Work, Bidder hereby proposes to (and, if awarded the Contract, the Bidder shall) furnish at its own cost and expense any and all labor, materials, tools, equipment, facilities, transportation, services and other things required for completion of the Project in strict conformity with the Bid Documents, in exchange for payment from the District of the total, all-inclusive amount(s):

Base Bid:

\_\_\_\_\_ Dollars (\$ \_\_\_\_\_).

- E. The Bidder acknowledges that it received, and that it fully considered when preparing this bid and determining the bid amount(s) proposed by the Contractor herein ("Bid Amounts"), each of the following Addenda to the Bid Documents (check all that apply; note, this Bid Proposal may be rejected as non-responsive if the Bidder checks any addendum that the District or Architect did not actually issue):

- |   |   |   |   |
|---|---|---|---|
| <input type="checkbox"/> Addendum No. 1 | <input type="checkbox"/> Addendum No. 2 | <input type="checkbox"/> Addendum No. 3 | <input type="checkbox"/> Addendum No. 4 |
| <input type="checkbox"/> Addendum No. 5 | <input type="checkbox"/> Addendum No. 6 | <input type="checkbox"/> Addendum No. 7 | <input type="checkbox"/> Addendum No. 8 |

- F. The Bidder acknowledges that the Bid Amounts shall constitute all-inclusive compensation in exchange for full and satisfactory completion of all of the Work, including, without limitation, compensation for any and all sales taxes, supervision, general conditions, fees, field-office and home-office overhead, and profit.
- G. The Bidder represents and warrants that it was responsible for preparing this bid and that it has carefully checked and confirmed the Bid Amounts and all other information set forth in this Bid Proposal. The Bidder acknowledges and agrees that the District may rely on such information and in no event shall the District Board or the District be responsible for any errors or omissions in this bid. The Bidder is aware and acknowledges that the District Board has the right to waive any minor irregularity in this bid, any other bid, or all bids for the Project.
- H. The Bidder has completed as applicable, executed, and submitted with this Bid Proposal all of the other Required Bid Forms. The Bidder acknowledges that the District shall deem this bid to be non-responsive if the Bidder fails to complete as applicable, execute, and submit any such other forms to the District concurrently with submitting this Bid Proposal.
- I. If awarded the Contract, the Bidder shall execute the Contract by causing its duly authorized representative to sign the Agreement for Construction Services, and thereby bind the Bidder to the Contract. The Bidder acknowledges that its bid security submitted concurrently herewith was given to guarantee that, if awarded the Contract, then, within seven calendar days of receipt of the Notice of Award, the Bidder shall complete as applicable, execute, and submit to the District: (i) the Agreement for Construction Services, Payment Bond, Performance Bond, and all other Required Contract Forms; and (ii) all Certificates of Insurance and endorsements required by the Contract Documents. The Bidder further acknowledges that it shall forfeit up to the whole amount of its bid security in the event Bidder fails to timely complete as applicable, execute, and submit any such documents to the District.
- J. The Bidder is, and if awarded the Contract, then at all times during the performance of Work must be, in full compliance with the provisions of the Immigration Reform and Control Act of 1986 ("IRCA") relating to its employees, and the Bidder shall indemnify, hold harmless and defend the District against any and all claims, actions, other proceedings, penalties, costs and expenses (including, without limitation, attorneys' fees), and other liabilities of any nature whatsoever that arise out of the Bidder's failure to strictly comply with the IRCA.
- K. The contact information set forth below is the current address and telephone number for the Bidder. The Bidder acknowledges that, if the District attempts to contact the Bidder for any purpose relating to this bid (including, without limitation, to request additional information or to provide a Notice of Award), but the District is unable to reach the Bidder because information set forth below is not correct, then the District may reject this bid and, in such event, the District shall have no liability to the Bidder whatsoever.

Bidder Street Address: \_\_\_\_\_  
 \_\_\_\_\_  
 \_\_\_\_\_

Telephone Number: \_\_\_\_\_



L. The Bidder is organized as a (check only one):  
 Corporation                       Limited Liability Company       General Partnership  
 Sole Proprietorship               Other (describe): \_\_\_\_\_

M. The Bidder is organized pursuant to the laws of the State of: \_\_\_\_\_

N. The Bidder acknowledges and agrees that, unless it withdraws this bid in accordance with the Instructions For Bidders prior to the Bid Deadline, the Bidder may not withdraw this bid for a period of sixty days after the Bid Deadline.

Representative Name: \_\_\_\_\_

Representative Title: \_\_\_\_\_

Representative Signature: \_\_\_\_\_

Date Signed: \_\_\_\_\_

## SUBCONTRACTOR LISTING

**District:** Solana Beach School District

**Project:** Skyline Backstop Upgrades

**Bid Package No.:** 2211

**Bidding Contractor ("Bidder"):** \_\_\_\_\_

---

The undersigned hereby certifies to the District, subject to penalty for perjury pursuant to the laws of the State of California, that all of the following is true and correct:

- (i) The undersigned is a duly authorized representative of the Bidder and, in that capacity, has executed this certification on behalf of the Bidder.
- (ii) The Bidder knows and understands the provisions of the Subletting and Subcontracting Fair Practices Act (Public Contract Code Section 4100 *et seq.*), including, without limitation, the consequences of not listing any subcontractor, or listing more than one subcontractor, for any portion of the work on the Project.
- (iii) The Bidder is aware and acknowledges that, if bid alternates are required, and the Bidder intends to use different or additional subcontractors for any of the bid alternates, the Bidder must submit a separate, complete list of subcontractors for each such bid alternate.
- (iv) All subcontractors that the Bidder will use, if awarded a contract for work on the Project, are listed on the following Attachment Sheet(s), and the Bidder represents and warrants that each such subcontractor shall be duly and appropriately licensed by the Contractors State License Board of the State of California prior to commencing any of the Work.
- (v) The Bidder is aware and acknowledges that, not later than twenty-four hours following the bid deadline, the Bidder must submit to the District, in writing, the address, telephone number, and contact person's first and last name, for each listed subcontractor.
- (vi) The Bidder is aware and acknowledges that, if awarded a contract for work on the Project, the Bidder shall not, without the District's written consent: (i) substitute any subcontractor in place of a listed subcontractor; (ii) permit any subcontract for work on the Project to be assigned or transferred; (iii) allow any such work, labor or service to be performed by anyone other than the applicable listed subcontractor; or (iv) sublet or subcontract any of the work in excess of one-half of one percent of Bidder's total bid for which the Bidder did not list a subcontractor.

Representative Name: \_\_\_\_\_

Representative Title: \_\_\_\_\_

Representative Signature: \_\_\_\_\_

Date Signed: \_\_\_\_\_

**Note:** This certification page must be accompanied by the list of subcontractors on the following attachment sheet. Make and use copies of the attachment sheet, as necessary to list additional subcontractors.

## SUBCONTRACTOR LISTING – ATTACHMENT SHEET

**District:** Solana Beach School District

**Project:** Skyline Backstop Upgrades

**Bid Package No.:** 2211

**Bidding Contractor:** \_\_\_\_\_

**Attachment Sheet** \_\_\_\_\_ **of** \_\_\_\_\_

---

1. Subcontractor Name: \_\_\_\_\_ CSLB License No.: \_\_\_\_\_  
Location of Business: \_\_\_\_\_  
Portion of Work: \_\_\_\_\_
  
2. Subcontractor Name: \_\_\_\_\_ CSLB License No.: \_\_\_\_\_  
Location of Business: \_\_\_\_\_  
Portion of Work: \_\_\_\_\_
  
3. Subcontractor Name: \_\_\_\_\_ CSLB License No.: \_\_\_\_\_  
Location of Business: \_\_\_\_\_  
Portion of Work: \_\_\_\_\_
  
4. Subcontractor Name: \_\_\_\_\_ CSLB License No.: \_\_\_\_\_  
Location of Business: \_\_\_\_\_  
Portion of Work: \_\_\_\_\_
  
5. Subcontractor Name: \_\_\_\_\_ CSLB License No.: \_\_\_\_\_  
Location of Business: \_\_\_\_\_  
Portion of Work: \_\_\_\_\_
  
6. Subcontractor Name: \_\_\_\_\_ CSLB License No.: \_\_\_\_\_  
Location of Business: \_\_\_\_\_  
Portion of Work: \_\_\_\_\_
  
7. Subcontractor Name: \_\_\_\_\_ CSLB License No.: \_\_\_\_\_  
Location of Business: \_\_\_\_\_  
Portion of Work: \_\_\_\_\_

## BID BOND

**School District:** Solana Beach School District of San Diego County, California

**Project:** Skyline Backstop Upgrades

**Bid Package No.:** 2211

**Contractor** (insert full legal name): \_\_\_\_\_

**Surety** (insert full legal name): \_\_\_\_\_

**Penal Sum:** Ten percent (10%) of Contractor's Total Bid Amount

---

The Contractor (identified above and referred to herein as, the "Principal") has provided this bid bond in connection with the bid submitted by the Principal to the School District (identified above) for the construction of the public works project identified above ("Project").

In issuing this bid bond, the Surety (identified above) shall be deemed and construed to thereby certify to the School District that the Surety is "an admitted surety insurer" as defined in California Code of Civil Procedure Section 995.120.

We, the Principal and the Surety, as evidenced by the signatures of our respective duly authorized representatives set forth below, are hereby held and firmly bound unto the School District in the amount of the Penal Sum specified above, for the payment of which amount, well and truly to be made, we hereby jointly and severally bind ourselves, our heirs, executors, administrators, successors, and assigns as specified below.

The payment obligation described above shall become null and void if: (i) the School District awards the contract for construction of the Project ("Contract") to the Principal based on the bid described above and, within the required number of days after the notice of such award, the Principal enters into the Contract and provides to the School District the required payment and performance bonds, and other required documentation; (ii) the School District rejects all bids received for the Project; or (iii) the Principal withdraws its bid following expiration of the time period during which bids may not be withdrawn.

If, however, the School District awards the Contract to the Principal, but the Principal fails and/or refuses to enter into the Contract and/or to properly and duly execute and deliver the required payment bond, performance bond, and/or other required documentation, then, immediately upon request of the School District and without imposing any additional conditions on payment whatsoever, the Surety and/or the Principal shall forfeit and pay to the School District such amount as the School District states is the total of the costs reasonably incurred by the School District as a result of such failure or refusal by the Principal, including, without limitation, the difference between the Principal's bid and the bid for the Project subsequently accepted by the School District, rebidding of the Project if necessary, and administrative, publication, and other costs incurred by the School District. In no event, however, shall the liability pursuant to this bid bond exceed the Penal Sum specified above.

The Surety, for value received, hereby stipulates and agrees that this bid bond and the Surety's obligations hereunder shall be and remain in effect until such time as one or more of the conditions described herein for rendering this bid bond null and void have been satisfied. The Surety, for value received, further stipulates and agrees that this bid bond shall in no way be impaired or otherwise

affected by any extension of the time within which the School District may accept the Principal's bid for the Project or of the time within which the Principal must enter into the Contract and submit the required documentation, and Surety hereby waives any requirement for notice of any such extension.

Each person signing this bid bond on behalf of either the Principal or the Surety hereby represents and warrants that he or she has been duly authorized to sign, and thereby bind such party to, this bid bond.

IN WITNESS WHEREOF, the Principal and Surety, acting by and through their respective, duly authorized representatives, have executed this instrument on the date indicated below and affixed the name and, if applicable, corporate seal of each party.

Principal: \_\_\_\_\_  
(Corporate or Individual Name)

Business Address: \_\_\_\_\_  
\_\_\_\_\_  
\_\_\_\_\_

Authorized Signature: \_\_\_\_\_ (Affix Corporate Seal)  
(Must be Notarized)

Date Signed: \_\_\_\_\_

---

Surety: \_\_\_\_\_  
(Corporate Name)

Business Address: \_\_\_\_\_  
\_\_\_\_\_  
\_\_\_\_\_

Authorized Signature: \_\_\_\_\_ (Affix Corporate Seal)  
(Must be Notarized)

Date Signed: \_\_\_\_\_

---

*(The following is to be completed by Surety.)*

The rate of premium on this bond is: \$ \_\_\_\_\_ per thousand dollars.

Total amount of premium charged is: \$ \_\_\_\_\_.

---

**Note:** A certified copy of the Power of Attorney of the Surety's authorized signatory must be attached to this bid bond.

## CERTIFICATION REGARDING DVBE EFFORTS

**District:** Solana Beach School District

**Project:** Skyline Backstop Upgrades

**Bid Package No.:** 2211

**Contractor:** \_\_\_\_\_

---

The undersigned hereby certifies to the District, subject to penalty for perjury pursuant to the laws of the State of California, that: (i) the undersigned is a duly authorized representative of the Contractor and, in that capacity, has executed this certification on behalf of the Contractor; and (ii) the Contractor made reasonable efforts, as required by the Contract, to secure participation in the Contract by Disabled Veteran Business Enterprises ("DVBE"), including participation by DVBE subcontractors, material suppliers, and others. The undersigned further certifies, on behalf of the Contractor, as follows:

**CHECK ONLY ONE OF THE FOLLOWING:**

- THE CONTRACTOR DID NOT SECURE DVBE PARTICIPATION IN THE CONTRACT. However, the Contractor will use DVBE services if the opportunity reasonably arises at any time during construction of the Project. Upon completion of the Project and as a condition precedent to final payment to the Contractor pursuant to the Contract, the Contractor will report to the District the total dollar amount of DVBE participation in the Contract, including, without limitation, any work performed pursuant to Change Orders applicable to the Project.
  
- THE CONTRACTOR DID SECURE DVBE PARTICIPATION IN THE CONTRACT, AS DESCRIBED ON THE ATTACHMENT SHEET(S) ATTACHED HERETO. The Contractor will use additional DVBE services if the opportunity reasonably arises at any time during construction of the Project. Upon completion of the Project and as a condition precedent to final payment to the Contractor pursuant to the Contract, the Contractor will report to the District the actual total dollar amount of DVBE participation in the Contract, including, without limitation, any work performed pursuant to Change Orders applicable to the Project.

Representative Name: \_\_\_\_\_

Representative Title: \_\_\_\_\_

Representative Signature: \_\_\_\_\_

Date Signed: \_\_\_\_\_

## CERTIFICATION REGARDING DVBE EFFORTS – ATTACHMENT SHEET

**District:** Solana Beach School District

**Project:** Skyline Backstop Upgrades

**Bid Package No.:** 2211

**Contractor:** \_\_\_\_\_

---

1. DVBE Entity Name: \_\_\_\_\_

State DVBE Certification No.: \_\_\_\_\_ Telephone No.: \_\_\_\_\_

Business Address: \_\_\_\_\_

Anticipated Participation in Contract: \$ \_\_\_\_\_

Type of Participation: \_\_\_\_\_

2. DVBE Entity Name: \_\_\_\_\_

State DVBE Certification No.: \_\_\_\_\_ Telephone No.: \_\_\_\_\_

Business Address: \_\_\_\_\_

Anticipated Participation in Contract: \$ \_\_\_\_\_

Type of Participation: \_\_\_\_\_

3. DVBE Entity Name: \_\_\_\_\_

State DVBE Certification No.: \_\_\_\_\_ Telephone No.: \_\_\_\_\_

Business Address: \_\_\_\_\_

Anticipated Participation in Contract: \$ \_\_\_\_\_

Type of Participation: \_\_\_\_\_

4. DVBE Entity Name: \_\_\_\_\_

State DVBE Certification No.: \_\_\_\_\_ Telephone No.: \_\_\_\_\_

Business Address: \_\_\_\_\_

Anticipated Participation in Contract: \$ \_\_\_\_\_

Type of Participation: \_\_\_\_\_

**Note:** Types of DVBE participation may include, but are not limited to: (i) construction; (ii) architectural and/or engineering; (iii) suppliers of materials, equipment and/or supplies; and (iv) information technology.

## NON-COLLUSION DECLARATION

**District:** Solana Beach School District

**Project:** Skyline Backstop Upgrades

**Bid Package No.:** 2211

**Contractor:** \_\_\_\_\_

---

The undersigned hereby declares:

I am the \_\_\_\_\_ (insert position) of \_\_\_\_\_  
\_\_\_\_\_ (insert Contractor name), the party making the foregoing bid.

The bid is not made in the interest of, or on behalf of, any undisclosed person, partnership, company, association, organization, or corporation. The bid is genuine and not collusive or sham. The bidder has not directly or indirectly induced or solicited any other bidder to put in a false or sham bid. The bidder has not directly or indirectly colluded, conspired, connived, or agreed with any bidder or anyone else to put in a sham bid, or to refrain from bidding. The bidder has not in any manner, directly or indirectly, sought by agreement, communication, or conference with anyone to fix the bid price of the bidder or any other bidder, or to fix any overhead, profit, or cost element of the bid price, or of that of any other bidder. All statements contained in the bid are true.

The bidder has not, directly or indirectly, submitted his or her bid price or any breakdown thereof, or the contents thereof, or divulged information or data relative thereto, to any corporation, partnership, company, association, organization, bid depository, or to any member or agent thereof, to effectuate a collusive or sham bid, and has not paid, and will not pay, any person or entity for such purpose.

Any person executing this declaration on behalf of a bidder that is a corporation, partnership, joint venture, limited liability company, limited liability partnership, or any other entity, hereby represents that he or she has full power to execute, and does execute, this declaration on behalf of the bidder.

I declare under penalty for perjury under the laws of the State of California that the foregoing is true and correct and that this declaration is executed on \_\_\_\_\_ (insert date), at \_\_\_\_\_ (insert city), \_\_\_\_\_ (insert state).

Representative Name: \_\_\_\_\_

Representative Signature: \_\_\_\_\_

Date Signed: \_\_\_\_\_



## CERTIFICATION REGARDING SITE VISIT

**District:** Solana Beach School District

**Project:** Skyline Backstop Upgrades

**Bid Package No.:** 2211

**Contractor:** \_\_\_\_\_

**Site Visit Date(s):** \_\_\_\_\_

---

The undersigned hereby certifies to the District, subject to penalty for perjury pursuant to the laws of the State of California, that the following is true and correct:

- (i) The undersigned is a duly authorized representative of the Bidder and, in that capacity, has executed this certification on behalf of the Bidder.
- (ii) I have sufficient knowledge, experience and/or resources to have undertaken the activities and reached the conclusions described and set forth in this Certification Regarding Site Visit.
- (iii) On the Site Visit Date(s) specified above, I inspected the Project Site and all conditions at the Project Site that will or might affect the performance of the Work or the portion thereof to be performed by the Bidder if awarded the Contract, including, without limitation: (a) the general shape, layout, slope, crossfall and other features of the Project Site; (b) any right-of-way and access limitations affecting the Project Site; (c) any existing buildings, hardscape, paving and other improvements on, at or in the vicinity of the Project Site; (d) any encroachments on the Project Site; (e) any manholes, pullboxes, valves and valveboxes, backflow preventers, stormdrain inlets and outlets, and/or similar features on, at or in the vicinity of the Project Site that may indicate the presence of subsurface utilities or other improvements on the Project Site; (f) any reasonably apparent past or present uses of the Project Site, and reasonably apparent age or condition of any improvements on or at the Project Site, that may indicate presence of any asbestos, lead or other hazardous materials on or at the Project Site; and (g) any mature trees or other vegetation, natural drainage or watercourses, or other landscape features on or in the vicinity of the Project Site.
- (iv) I am fully acquainted with all conditions that will affect the Work or the portion thereof to be performed by the Bidder if awarded the Contract, and I fully understand the facilities, difficulties, and restrictions attending the execution of such Work; and such understanding is hereby attributed to and deemed to be the understanding of the Bidder.
- (v) In connection with the Work or the portion thereof to be performed by the Bidder if awarded the Contract, the Bidder accepts full responsibility for all conditions on, at or in the vicinity of the Project Site affecting such Work, including, without limitation, any as described herein, that reasonably could have been observed or identified during my visit to the Project Site.

Representative Name: \_\_\_\_\_

Representative Title: \_\_\_\_\_

Representative Signature: \_\_\_\_\_

Date Signed: \_\_\_\_\_

## CERTIFICATION REGARDING CONTRACTOR REGISTRATION

**District:** Solana Beach School District

**Project:** Skyline Backstop Upgrades

**Bid Package No.:** 2211

**Contractor:** \_\_\_\_\_

---

The undersigned hereby certifies to the District, subject to penalty for perjury pursuant to the laws of the State of California, that all of the following is true and correct:

- (i) The undersigned is a duly authorized representative of the Contractor and, in that capacity, I has executed this certification on behalf of the Contractor.
- (ii) The Contractor is aware and acknowledges that, except as authorized by Business and Professions Code Section 7029.1 and Public Contract Code Section 20103.5, no contractor may submit a bid for any work on a public works project unless the contractor is, and no subcontractor may be listed in any bid for work on a public works project unless the subcontractor is, currently registered with the DIR and qualified to perform public work pursuant to Labor Code Section 1725.5.
- (iii) The Contractor is aware and acknowledges that, no contractor or subcontractor may be awarded a contract for work on a public works project, or may perform any work on a public works project, unless the contractor or subcontractor is currently registered with the DIR and qualified to perform public work pursuant to Labor Code Section 1725.5.
- (iv) The Contractor is aware and acknowledges that, notwithstanding anything to the contrary, if awarded the Contract and at any time during the performance of the Work, the Contractor or any of its subcontractors is not duly registered pursuant to Labor Code Section 1725.5 (including, without limitation, if the registration expires or the DIR revokes the registration), the District in its sole discretion may cancel the Contract and/or replace the Contractor or subcontractor with a contractor or subcontractor that is duly registered pursuant to Labor Code Section 1725.5, and the Contractor and/or its surety shall be responsible for any and all associated costs incurred by the District.
- (v) If awarded the Contract, and the Contractor at any time during the Project intends to use a subcontractor that was not listed in its bid (e.g., a subcontractor performing work costing less than one-half of one percent of the Contractor's total bid amount or a subcontractor needed for work added by change order), then, before the subcontractor performs any work on the Project, the Contractor must provide written notice to the District that identifies the subcontractor and includes the printout described at the bottom of this form as evidence that the subcontractor is properly registered with the DIR.
- (vi) The Contractor acknowledges that, if awarded the Contract, the Contractor must: (i) monitor the registration status of its subcontractors on a regular, ongoing basis; and (ii) inform the District in writing if any of its subcontractors is or becomes not duly registered.
- (vii) The Contractor and each subcontractor specified on the Subcontractor Listing accompanying the Contractor's bid are duly registered with the DIR pursuant to Labor Code Section 1725.5.

(viii) Evidence (in the form described in the note below) that the Contractor and each such subcontractor are duly registered with the DIR pursuant to Labor Code Section 1725.5 is attached to this certification.

Representative Name: \_\_\_\_\_

Representative Title: \_\_\_\_\_

Representative Signature: \_\_\_\_\_

Date Signed: \_\_\_\_\_

**Note:** This certification must be accompanied by printouts of the applicable screens on the DIR website evidencing that the Contractor and all listed subcontractors are currently registered pursuant to Labor Code Section 1725.5.

## REQUIRED CONTRACT FORMS

The Contractor must complete, duly execute, and submit the following forms to the District when required after award of the Contract:

1. Agreement for Construction Services
2. Certification Regarding Employee Background Checks
3. Certification Regarding Drug-Free Workplace
4. Certification Regarding Tobacco-Free Workplace
5. Certification Regarding Workers Compensation
6. Notice and Certification Regarding Lead-Free Materials
7. Certification Regarding Asbestos
8. Payment Bond
9. Performance Bond
10. Certification Regarding DVBE Participation

## AGREEMENT FOR CONSTRUCTION SERVICES

This Agreement for Construction Services is made effective as of January 20, 2022, by and between the Solana Beach School District (“District”), a public school district organized and existing pursuant to the laws of the State of California, and [Click here to enter Contractor’s full legal name](#) (“Contractor”), a [Click here to enter state in which Contractor organized and type of entity](#). The District and the Contractor may be referred to individually as “Party” and collectively as the “Parties.”

**Section 1. Project.** The Parties have entered into the Contract with respect to the following public works construction project of the District (“Project”): Skyline Backstop Upgrades

**Section 2. Component Parts of Contract.** The entire understanding and agreement between the District and the Contractor relating to the Project (the “Contract”) includes and by this reference incorporates in full all of the documents described in this Section (collectively, the “Contract Documents”). The Contract Documents are intended to be complementary and form an integrated and binding whole. Contractor shall perform the work required by any one of the Contract Documents, even if that work is not referenced in any other Contract Document, as if that work is required by each and every Contract Document. The Contract Documents include:

- (i) Notice Inviting Bids
- (ii) Instructions For Bidders
- (iii) Description of Work
- (iv) Master Schedule
- (v) All Required Bidding Forms, including, without limitation, Contractor’s completed and executed Bid Proposal form
- (vi) Notice of Award
- (vii) All plans, drawings, and specifications for the Project, including, without limitation, attachments thereto and any and all approved shop-drawing submittals (“Plans and Specifications”)
- (viii) All Required Contract Forms, including, without limitation, Contractor’s completed and executed Agreement for Construction Services
- (ix) Special Provisions
- (x) General Provisions
- (xi) Any and all Change Orders and other duly approved modifications to the Contract Documents
- (xii) Each addendum to the Plans and Specifications
- (xiii) Each response to Bidder Clarification Request

**Section 3. Scope of Work.** The Contractor shall, at its own cost and expense, furnish all construction and other services (including, but not limited to, all labor, materials, tools, equipment, services, administration, supervision, and incidental and customary work) necessary and appropriate to fully and adequately complete the Project in strict accordance with the Contract Documents (“Work”). Should any detail or dimension be inadvertently omitted from the Plans and Specifications, it shall be the Contractor’s responsibility to request from the Architect the required details or information and to perform the Work in conformance therewith so that, upon completion of the Work, it will be acceptable and ready for use by the District.

**Section 4. Completion of Work.** Time is of the essence with respect to completion of the Project. The Contract requires the exact and full performance of the Work by the Contractor. The District shall provide notice to the Contractor specifying the date upon which the Contractor is to

commence the Work (“Notice to Proceed”). Unless the time for performance is extended pursuant to the terms of the Contract, the Contractor shall complete all of the Work by the date specified in the Master Schedule. The Contractor acknowledges and agrees that: (i) it shall perform the Work in strict conformance with all schedule(s) or project milestone(s) set forth in the Master Schedule; and (ii) the Master Schedule is subject to revision depending on actual conditions in the field and other factors, and as otherwise provided by the Contract. The Contractor must perform the Work in full compliance with the Master Schedule, including, without limitation, as it may be revised in accordance with the Contract, without additional compensation except as may be permitted pursuant to the Contract Documents. The legal doctrine that a contractor may recover for a substantial performance of a building contract (i.e., “Doctrine of Substantial Performance”) shall not be deemed or construed to apply to the Contract.

**Section 5. Certification of Contractor’s License.** In entering into the Contract, the Contractor hereby certifies that as of the date of execution of the Contract, the Contractor possesses a current and valid contractor’s license issued by the Contractors State License Board of the State of California, license number [Click here to enter license number](#), classification(s) [Click here to enter classification number](#), which license the Contractor represents and warrants is appropriate for the Contractor, in conjunction with any subcontractors listed in the Bid Proposal, to perform the Work in accordance with California law.

**Section 6. Payment to Contractor.** In exchange for the full and satisfactory performance of the Work, the District shall pay to the Contractor the total, all-inclusive amount of [Click here to enter Contract Amount in words](#) ([\\$Click here to enter Contract Amount in numbers](#)) (“Contract Amount”). The Contract Amount shall be subject to adjustment as provided in the Contract Documents through authorized Change Orders approved by the District. Payments to the Contractor shall be made as the Work progresses (each a “Progress Payment”) based on Progress Payment Applications submitted by the Contractor and subject to Retention, as set forth in the General Provisions.

**Section 7. District Representative.** The authorized representative of the District for purposes of the administration of the Contract (“District Representative”) shall be Caroline Brown, Executive Director of Capital Programs, who may be reached at (858) 794-7130. With respect to the matters within the authority of the District Representative, the Contractor shall not accept any instruction or direction from any person purporting to represent the District other than the District Representative or his or her designee. Notwithstanding the foregoing, each of the District’s Superintendent and Assistant Superintendent of Business Services shall have the authority to act on behalf of the District for all purposes of the Contract, including, among other situations, if the District Representative is not available on a timely basis.

**Section 8. Notices.** Each notice, demand, and other communication required or given pursuant to the Contract must be in writing, duly addressed as indicated below, and given by: (i) personal delivery (signature on delivery receipt requested); (ii) registered or certified mail (postage prepaid and return receipt requested); or (iii) UPS, FedEx or other reliable private express delivery (delivery charge prepaid and signature on electronic or other delivery receipt requested). Such notices, demands or communications shall be deemed given, served, or received only upon actual receipt. This section shall not be deemed or construed to apply to day-to-day communications between the Parties for purposes of administering the Contract or performance of the Work, or to service of process in accordance with any applicable law or rule of court. Any Party to the Contract may change its below-specified name, address, or person to whom attention should be directed by giving notice as specified in

this Section. Notices, demands, and other communications, as applicable, shall be duly addressed as follows:

To the District:

Solana Beach School District  
Attn: Michael Hodson, Assistant Superintendent,  
Business Services  
309 North Rios Avenue  
Solana Beach, CA 92075

With Copy to:

Solana Beach School District  
Attn: Patrick Mason, Director,  
Facilities, Maintenance & Operations  
309 North Rios Avenue  
Solana Beach, CA 92075

To the Contractor:

[Click here to enter Contractor](#)  
Attn: [Click here to enter Representative name](#)  
[and title for purposes of Notices](#)  
[Click here to enter street](#)  
[Click here to enter city, state and zip](#)

Notwithstanding anything in the Contract to the contrary, in the event of any emergency or urgent situation, the Contractor must make reasonable attempts to contact the District Representative by telephone and shall follow up such telephone contact with written confirmation. Telephone numbers for "after hours" communications are:

District Representative: [Click here to enter telephone number](#)  
Contractor Representative: [Click here to enter telephone number](#)

The Contractor shall notify the District within five business days of any change in its address, facsimile number, or telephone number(s), and failure of Contractor to provide such notice shall be deemed a material breach of the Contract.

Pursuant to Public Contract Code Section 9201, the District will timely notify the Contractor of any third-party claim relating to the Contract by mailing notice of receipt of such claim within ten calendar days. Public Contract Code Section 9201 provides that the District shall be entitled to its reasonable costs incurred in providing this notice to the Contractor.

**Section 9. Attorneys' Fees.** In the event of any action or other proceeding to enforce the Contract and/or to resolve any dispute between the Parties related thereto, each Party shall be responsible for paying its own costs and expenses incurred in connection with such action or proceeding, including, without limitation, attorneys' fees and expenses.

**Section 10. Entire Agreement.** The Contract constitutes the entire agreement of the Parties with respect to the performance of the Work by the Contractor and supersedes any and all prior and contemporaneous communications, negotiations, understandings, and agreements related to the Work, whether oral or written. The Contract may be modified only by written instrument duly approved and signed by both Parties. Any provision, printed or otherwise, contained in any acknowledgment of the Contract or purchase order or invoice related to the Contract that is inconsistent with, different from, or in addition to the terms and conditions contained in the Contract or any documents specifically referenced and incorporated herein, shall have no force or effect whatsoever.

**Section 11. Assignment.** Contractor shall not assign, sublet or by any other means transfer the Contract or any obligation, right, title or interest herein, including right to payments hereunder, without the prior written consent of District. The Contract shall be binding on any authorized assignee, sublessee, transferee, or other successor to the Contractor. If Contractor attempts, without District permission, to assign, sublet or by any other means transfer the Contract or any obligation, right, title or interest herein, the District may, at its option, terminate the Contract and shall thereafter be relieved from any and all obligations to Contractor and any purported assignee, sublessee, or transferee.

**Section 12. Counterparts.** The Contract may be executed in counterparts, each of which shall constitute an original and all of which shall constitute but one and the same instrument.

**Section 13. Due Authority.** Each individual that signs the Contract on behalf of a Party thereby represents and warrants that he or she has been authorized by appropriate action of such Party to sign, and thereby bind such Party to, the Contract.

**In Witness Whereof,** the duly authorized representatives of the Parties have executed the Contract, as evidenced by their signatures below.

**Solana Beach School District**

**[Click here to enter Contractor](#)**

By: \_\_\_\_\_

By: \_\_\_\_\_

Print Name: \_\_\_\_\_

Print Name: \_\_\_\_\_

Title: \_\_\_\_\_

Title: \_\_\_\_\_

Dated: \_\_\_\_\_

Dated: \_\_\_\_\_



## CERTIFICATION REGARDING EMPLOYEE BACKGROUND CHECKS

**District:** Solana Beach School District

**Project:** Skyline Backstop Upgrades

**Bid Package No.:** 2211

**Contractor:** \_\_\_\_\_

---

The undersigned hereby certifies to the District, subject to penalty for perjury pursuant to the laws of the State of California, that the following is true and correct:

- (i) The undersigned is a duly authorized representative of the Contractor and, in that capacity, has executed this certification on behalf of the Contractor;
- (ii) The Contractor has fully complied with the requirements of Section 3.7 of the General Provisions for employee background checks, including, without limitation, with respect to employees of any subcontractors that the Contractor intends to use on the Project;
- (iii) All of the employees of the Contractor and its subcontractors who will enter in or upon the Project Site, or be in the vicinity of the Project Site, in connection with the Project are identified on the Attachment Sheet(s) attached hereto;
- (iv) None of the employees of the Contractor or its subcontractors who are identified on the Attachment Sheet(s) attached hereto have been convicted of a violent or serious felony as defined in Subdivision (c) of Education Code Section 45125.2; and
- (v) Except for the employees identified on the Attachment Sheet(s) attached hereto (and except for the employees identified on attachment(s) to other certifications using this form that the Contractor has submitted to the District in connection with the Project), the Contractor shall not suffer or permit any employees of the Contractor or any of its subcontractors to enter in or upon the Project Site, or to be in the vicinity of the Project Site, in connection with the Project.

Representative Name: \_\_\_\_\_

Representative Title: \_\_\_\_\_

Representative Signature: \_\_\_\_\_

Date Signed: \_\_\_\_\_

**Note:** The Contractor must attach this certification to the list(s) of employees prepared using the following Attachment Sheet.

## CERTIFICATION REGARDING EMPLOYEE BACKGROUND CHECKS – ATTACHMENT SHEET

**Contractor:** \_\_\_\_\_

**Instructions**

- (1) For each employee, insert all required information (as specified in the table below) in one row of the table.
- (2) In the “Driver License/Identification” column in the table below: (i) specify the number of the employee’s driver’s license or, if the employee does not have a driver’s license, the number of the employee’s state-issued identification; and (ii) specify the state that issued the driver’s license or identification.
- (3) If identifying more than ten employees: (i) use copies of this Attachment Sheet to identify the additional employees; and (ii) on each such copy, specify the sheet number and total number of sheets where indicated at the bottom of this Attachment Sheet.

	Employer (Company)	Employee Name and Position	Sex	Date of Birth	Height	Weight	Hair Color	Eye Color	Driver License/ Identification #
1									
2									
3									
4									
5									
6									
7									
8									
9									
10									

Attachment Sheet \_\_\_\_ of \_\_\_\_

## CERTIFICATION REGARDING DRUG-FREE WORKPLACE

**District:** Solana Beach School District

**Project:** Skyline Backstop Upgrades

**Bid Package No.:** 2211

**Contractor:** \_\_\_\_\_

---

The undersigned hereby certifies to the District, subject to penalty for perjury pursuant to the laws of the State of California, that the following is true and correct:

- (i) The undersigned is a duly authorized representative of the Contractor and, in that capacity, has executed this certification on behalf of the Contractor;
- (ii) The Contractor, in accordance with Government Code Section 8350 *et seq.*, the Drug-Free Workplace Act of 1990, shall provide a drug-free workplace by doing all of the following:
  - (a) Publishing a statement notifying employees that the unlawful manufacture, distribution, dispensation, possession or use of a controlled substance is prohibited in the person's or organization's workplace and specifying actions which will be taken against employees for violations of the prohibition.
  - (b) Establishing a drug-free awareness program to inform employees about all of the following:
    - (1) The dangers of drug abuse in the workplace;
    - (2) The person's or organization's policy of maintaining a drug-free workplace;
    - (3) The availability of drug counseling, rehabilitation and employee-assistance programs; and
    - (4) The penalties that may be imposed upon employees for drug abuse violations.
  - (c) Requiring that each employee engaged in the performance of the Contract be given a copy of the statement required by clause (ii)(a) above, and that, as a condition of employment on the Project, the employee agrees to abide by the terms of the statement.
- (iii) The Contractor hereby acknowledges and agrees that, if the District determines that the certification given herein is false, or the Contractor violated this certification by failing to implement the requirements of Government Code Section 8355, then the Contract shall be subject to termination, suspension of payments, or both, and the Contractor shall be subject to debarment in accordance with the requirements of Government Code Section 8350 *et seq.*

Representative Name: \_\_\_\_\_

Representative Title: \_\_\_\_\_

Representative Signature: \_\_\_\_\_

Date Signed: \_\_\_\_\_

## CERTIFICATION REGARDING TOBACCO-FREE WORKPLACE

**District:** Solana Beach School District

**Project:** Skyline Backstop Upgrades

**Bid Package No.:** 2211

**Contractor:** \_\_\_\_\_

---

The undersigned hereby certifies to the District, subject to penalty for perjury pursuant to the laws of the State of California, that the following is true and correct:

- (i) The undersigned is a duly authorized representative of the Contractor and, in that capacity, has executed this certification on behalf of the Contractor.
  
- (ii) The Contractor shall ensure a tobacco-free workplace by doing both of the following:
  - (a) Providing the following statement, in writing, to each person providing any labor or services on or at the Project Site, including, without limitation, any delivery personnel:

All properties and facilities operated by the Solana Beach School District, including, without limitation, the Project Site, are tobacco-free work places. It is strictly forbidden while in, on or at any District property or facility (whether owned or leased) to smoke, chew or otherwise use tobacco products. The Contractor shall require each person (including, without limitation, any employee of the Contractor or any subcontractor or supplier) found in violation of these requirements to permanently leave the Project Site, and the Contractor shall not thereafter permit such person to be present in, on, or at the Project Site.

- (b) Enforcing the requirements specified in the foregoing provision.

Representative Name: \_\_\_\_\_

Representative Title: \_\_\_\_\_

Representative Signature: \_\_\_\_\_

Date Signed: \_\_\_\_\_

## CERTIFICATION REGARDING WORKERS COMPENSATION

**District:** Solana Beach School District

**Project:** Skyline Backstop Upgrades

**Bid Package No.:** 2211

**Contractor:** \_\_\_\_\_

---

The undersigned hereby certifies to the District, subject to penalty for perjury pursuant to the laws of the State of California, that all of the following is true and correct:

- (i) The undersigned is a duly authorized representative of the Contractor and, in that capacity, has executed this certification on behalf of the Contractor; and
  
- (ii) The Contractor is aware of the provisions of Labor Code Section 3700 *et seq.*, which require every employer to be insured against liability for Workers' Compensation or to undertake self-insurance in accordance with the provisions of the Labor Code, and the Contractor shall comply with such provisions prior to commencing and throughout the entirety of performance of the Work on the Project.

Representative Name: \_\_\_\_\_

Representative Title: \_\_\_\_\_

Representative Signature: \_\_\_\_\_

Date Signed: \_\_\_\_\_

## NOTICE AND CERTIFICATION REGARDING LEAD-FREE MATERIALS

**District:** Solana Beach School District

**Project:** Skyline Backstop Upgrades

**Bid Package No.:** 2211

**Contractor:** \_\_\_\_\_

---

### NOTICE:

If the Work involves or relates to other than entirely new construction, the Work may disturb lead-containing or lead-based paint and other building materials that may be incorporated into existing buildings or other improvements located on the site for construction of the Project ("Project Site"). Until sampling and testing confirms otherwise, it shall be presumed that all school buildings and improvements built in 1992 or earlier contain lead-based or lead-containing paint. The Contractor must complete, sign and submit a copy of this Notice and Certification Regarding Lead-Free Materials to the District prior to commencing the Work.

The Contractor shall be responsible for ensuring that its employees and subcontractors fully and adequately comply with, and that the Work is performed in conformance with, all applicable laws, ordinances, rules and regulations governing lead-based or lead-containing paint and other materials, including, but not limited to: (i) Education Code Section 32240 *et seq.*; (ii) Title 8, California Code of Regulations, Section 1532.1; and (iii) Title 17, California Code of Regulations, Section 35001 *et seq.*

If the Work involves renovation, modernization or other disturbance of any existing school buildings or improvements, the Contractor shall sample and test all materials as appropriate to determine whether lead-based paint or other materials are present and may present a hazard or threat during any such renovation or modernization. The Contractor shall provide the District with the results of any and all such testing, whether conducted prior to commencement of the Work, during the Work, or after completion of the Work.

Any and all Work that may result in the disturbance of lead-containing building materials must be coordinated through the District. Consistent with applicable law, when a lead-based hazard is identified, the Contractor shall utilize personnel certified by the California Department of Health Services to perform lead-related services. The District may at any time request that Contractor provide the training and certification records of each employee of the Contractor or subcontractor who provides lead-related services. The Contractor shall be solely responsible for proper disposal, in conformance with all applicable laws, of any and all lead-containing, lead-based or hazardous waste products including, but not limited to, paint chips, residue, and any other material that may be exposed or disturbed during the course of the Work.

California law prohibits, in the construction of any new school facility or in the modernization or renovation of any existing school facility, the use of lead-containing or lead-based paint, plumbing, solders, and other materials that may constitute a potential source of lead contamination.

In the event the Contractor or its employees or subcontractors fail to comply with all applicable laws, rules and regulations related to lead-containing or lead-based paints and other materials, or fail to comply with any other requirements set forth in this Notice and Certification Regarding Lead-Free

Materials, the Contractor shall be held solely responsible for any and all costs associated with any investigative and/or corrective actions deemed necessary by the District, and shall indemnify, defend and hold harmless the District, pursuant to the indemnification provisions of the Contract for the Work, with respect to any and all claims, demands, actions, damages, costs, expenses, and other liabilities arising therefrom.

**CERTIFICATION BY CONTRACTOR:**

The undersigned hereby certifies to the District, subject to penalty for perjury pursuant to the laws of the State of California, that all of the following is true and correct:

- (i) The undersigned is a duly authorized representative of the Contractor and, in that capacity, has executed this certification on behalf of the Contractor;
- (ii) The Contractor has received notice that, in circumstances described in this Notice and Certification Regarding Lead-Free Materials, lead-based paint and/or other lead-containing materials may be located on the Project Site;
- (iii) The Contractor has received notice that it must comply with all applicable laws, rules and regulations governing work with, and disposal of, such materials; and
- (iv) In connection with the performance of the Work, the Contractor shall comply with all laws, rules and regulations applicable to work with, and disposal of, lead-based paint and/or other lead-containing materials, as well as the other requirements of this Notice and Certification Regarding Lead-Free Materials.

Representative Name: \_\_\_\_\_

Representative Title: \_\_\_\_\_

Representative Signature: \_\_\_\_\_

Date Signed: \_\_\_\_\_

## CERTIFICATION REGARDING ASBESTOS

**District:** Solana Beach School District

**Project:** Skyline Backstop Upgrades

**Bid Package No.:** 2211

**Contractor:** \_\_\_\_\_

---

The undersigned hereby certifies to the District, subject to penalty for perjury pursuant to the laws of the State of California that all of the following is true and correct:

- (i) The undersigned is a duly authorized representative of the Contractor and, in that capacity, has executed this certification on behalf of the Contractor.
- (ii) The Contractor is aware and acknowledges that, for purposes of this certification: (a) asbestos is any of chrysotile, crocidolite, amosite, anthophyllite, tremolite, actinolite or other minerals generally known as asbestos; and (b) an asbestos-containing material is any material or thing, or any component thereof, that contains, consists of, or is made up of greater than one-tenth of one percent (0.1%) asbestos.
- (iii) The Contractor shall not use on, or incorporate into, the Project any asbestos or asbestos-containing materials, including, without limitation, in any tools, devices, clothing, or equipment used in the construction of any portion of the Project.
- (iv) The Contractor has instructed its employees and subcontractors in regard to such prohibition against asbestos and asbestos-containing materials, and in regard to the hazards, risks and liabilities involved in the use of asbestos and asbestos-containing materials.
- (v) The Contractor acknowledges and agrees that:
  - (a) Each dispute as to whether any material, equipment or other thing used on, or incorporated into, the Work contains asbestos or is an asbestos-containing material shall be settled by electron microscopy;
  - (b) The costs of any such tests shall be paid by the Contractor if the material is found to contain asbestos at a level greater than as specified herein; and
  - (c) The District shall reject any and all materials or other things incorporated into the Work that are determined to contain asbestos or asbestos-containing materials, and the Contractor, at no cost to the District, must remove, replace and/or repair as necessary any and all affected portions of the Work.

Representative Name: \_\_\_\_\_

Representative Title: \_\_\_\_\_

Representative Signature: \_\_\_\_\_

Date Signed: \_\_\_\_\_



## PAYMENT BOND

**School District:** Solana Beach School District of San Diego County, California

**Project:** Skyline Backstop Upgrades

**Contractor:** \_\_\_\_\_

**Surety:** \_\_\_\_\_

**Bond #:** \_\_\_\_\_

**Penal Sum:** \_\_\_\_\_ (\$ \_\_\_\_\_)

---

**WHEREAS**, the Project identified above is a public project and a public work in accordance with applicable law, and the School District identified above awarded to the Contractor identified above (herein, the "Principal") a contract providing for completion of the Project identified above ("Contract");

**WHEREAS**, the Contract and/or California Civil Code Section 9550 *et seq.* require that the Principal furnish a labor and materials payment bond to the School District that ensures the faithful performance of the Principal's obligations pursuant to the Contract to pay for materials, labor and other things as required by applicable law, which bond must have a penal sum equal to one hundred percent of the total amount payable by the School District to the Principal pursuant to the Contract; and

**WHEREAS**, the Surety identified above hereby represents to the School District that the Surety is an "admitted surety insurer" in accordance with Section 995.120 of the California Code of Civil Procedure;

**NOW, THEREFORE**, we, the Principal and Surety, are hereby held and firmly bound to the School District in an amount of lawful money of the United States of America equal to the Penal Sum specified above, the payment of which well and truly to be made, we hereby bind, jointly and severally, ourselves and our heirs, executors, administrators, and successors.

The condition of this obligation is that, if the Principal, or any of its heirs, executors, administrators, successors or assigns, or any of its subcontractors, fail in connection with the Project to pay as and when required (1) any of the persons authorized by California Civil Code Section 9100 to assert a claim against the Payment Bond, (2) amounts due under the Unemployment Insurance Code with respect to work or labor performed pursuant to the Contract, or (3) any amounts required to be deducted, withheld and paid over to the Employment Development Department from wages of employees of the Principal or any of its subcontractors pursuant to Section 13020 of the Unemployment Insurance Code with respect to such work and labor, then the Surety shall pay, in full, any and all claims for such amounts, in a total amount not in excess of the penal sum set forth herein, and also, in case suit is brought upon this Payment Bond, such reasonable attorneys' fees as fixed by the court.

This Payment Bond shall inure to the benefit of any and all of the persons named in California Civil Code Section 9100, so as to give a right of action to those persons or their assigns in any suit brought upon this Payment Bond.

The Surety hereby stipulates and agrees that this Payment Bond shall not be exonerated and the Surety shall not be released from its obligations pursuant to this Payment Bond on account of: (1) any extension of time, change, amendment or other modification of the Contract or other Project documents, or of the Principal's rights and/or obligations pursuant thereto, and Surety hereby waives

notice of any and all such modifications; (2) any rescission or attempted rescission of the Contract or this Payment Bond; (3) any fraud of any person or entity other than fraud of a claimant in connection with making a claim on this Payment Bond; or (4) any breach of any contract by the School District, the Principal or any person or entity for whose benefit Surety has issued this Payment Bond. The Surety further stipulates and agrees that this Payment Bond shall be construed most strongly against the Surety and in favor of the persons and entities for whose benefit Surety has issued this Payment Bond.

The Surety shall not be deemed to have fully and appropriately executed this Payment Bond unless Surety has provided all of the following information:

**SURETY'S SOUTHERN CALIFORNIA/LOCAL REPRESENTATIVE**

**SURETY'S REPRESENTATIVE FOR FILING CLAIMS**

\_\_\_\_\_  
Company Name

\_\_\_\_\_  
Company Name

\_\_\_\_\_  
Street Address

\_\_\_\_\_  
Street Address

\_\_\_\_\_  
City, State, Zip Code

\_\_\_\_\_  
City, State, Zip Code

\_\_\_\_\_  
Representative Name

\_\_\_\_\_  
Representative Name

\_\_\_\_\_  
Representative Telephone Number

\_\_\_\_\_  
Representative Telephone Number

***(The remainder of this page intentionally left blank.)***

Each person that signs this Payment Bond on behalf of the Principal or the Surety thereby represents and warrants that the party he or she represents has duly authorized him or her to sign, and thereby bind such party to, this Payment Bond.

**IN WITNESS WHEREOF**, the Principal and Surety have executed this Payment Bond as evidenced by the signatures below of their respective, duly authorized representatives.

**PRINCIPAL**

**SURETY**

\_\_\_\_\_  
Company Name

\_\_\_\_\_  
Company Name

\_\_\_\_\_  
Representative Signature

\_\_\_\_\_  
Representative Signature

\_\_\_\_\_  
Representative Name

\_\_\_\_\_  
Representative Name

\_\_\_\_\_  
Representative Title

\_\_\_\_\_  
Representative Title

\_\_\_\_\_  
Date Signed

\_\_\_\_\_  
Date Signed

**Principal: Attach Notary acknowledgment to this Payment Bond and, if applicable, imprint corporate seal in the space below this line.**

**Surety: Attach Notary acknowledgment and power of attorney to this Payment Bond and imprint corporate seal in the space below this line.**

## PERFORMANCE BOND

**School District:** Solana Beach School District of San Diego County, California

**Project:** Skyline Backstop Upgrades

**Contractor:** \_\_\_\_\_

**Surety:** \_\_\_\_\_

**Bond #:** \_\_\_\_\_

**Penal Sum:** \_\_\_\_\_ (\$ \_\_\_\_\_)

**WHEREAS,** the Project identified above is a public project and a public work in accordance with applicable law, and the School District identified above awarded to the Contractor identified above (herein, the “Principal”) a contract providing for completion of the Project identified above (“Contract”);

**WHEREAS,** the Contract requires that the Principal furnish a bond to the School District that ensures the faithful performance of the Principal’s obligations pursuant to the Contract to fully and satisfactorily perform the work and services required by the Contract (collectively, the “Work”), which bond must have a penal sum equal to one hundred percent of the total amount payable by the School District to the Principal pursuant to the Contract; and

**WHEREAS,** the Surety identified above hereby represents and warrants to the School District that the Surety is an “admitted surety insurer” in accordance with Section 995.120 of the California Code of Civil Procedure;

**NOW, THEREFORE,** we, the Principal and Surety, are hereby held and firmly bound to the School District in an amount of lawful money of the United States of America equal to the Penal Sum specified above, the payment of which well and truly to be made, we hereby bind, jointly and severally, ourselves and our heirs, executors, administrators, and successors.

The condition of the foregoing payment obligation is that, if the Principal (or, to the extent permitted by the Contract, its heirs, executors, administrators, successors or assigns) shall fully perform all of the undertakings, terms, covenants, conditions, agreements and other obligations required of the Principal pursuant to the Contract and any amendments or changes thereto, and shall complete the Work in full and strict conformance with the requirements thereof, all within the time and in the manner designated therein, in all respects according to their true intent and meaning, then such obligation shall become null and void; otherwise, it shall remain in full force and effect.

A condition precedent to the satisfactory completion of the Contract is that, after the acceptance of the Project by the School District, the payment obligation of this Performance Bond shall remain in full force and effect, in the penal sum set forth herein, during all periods in which the Principal has any obligations pursuant to the Contract (including, without limitation, the obligations to make full, complete, and satisfactory repair and replacements of any defective materials and/or faulty workmanship, to pay liquidated damages and/or to indemnify the School District or any other party), and the obligation of Surety hereunder shall continue so long as any such obligation of Principal continues to exist. The obligations of Surety pursuant to this Performance Bond are exclusive of and distinct from any obligations Surety may have pursuant to any labor and materials payment bond applicable to the Work.

Whenever the School District declares the Principal to be in default of its obligations pursuant to the Contract, the School District having performed its obligations thereunder, the Surety, promptly within the time required by the Contract, shall remedy the default or, at the School District's discretion, shall:

- (i) Complete the Work in strict accordance with the terms and conditions of the Contract, including, without limitation, provisions for the time(s) within which the Surety must act; or
- (ii) Obtain, or permit the School District to obtain, one or more bids or proposals for any and all work required to complete the Work in strict accordance with the terms and conditions of the Contract, and upon determination of each lowest responsive and responsible bidder or proposer, arrange for such bidder or proposer and the School District to enter into a contract (which, without limitation, may be in accordance with Education Code Section 17406), and make available as the work progresses sufficient funds, up to and including a total amount equal to the Penal Sum set forth above, to pay the cost of completing the Work.

In performing its obligations pursuant to this Performance Bond, the Surety expressly agrees that: (i) absent the express written consent of the School District, the Surety shall neither use the Principal nor accept a bid or proposal from the Principal for purposes of completing the Work; and (ii) the School District shall have the right, in its reasonable discretion, to reject any contractor or subcontractor that the Surety may propose to fulfill such obligations. In the event the School District provides notice to the Surety that the Principal is in default of its obligations pursuant to the Contract and, therefore, the Surety is required, as provided herein, to complete the Work or to arrange for the School District to contract for completion of the Work, and, through no fault of the School District, the Surety has exceeded the time permitted pursuant to the Contract for doing so, the School District may arrange to use replacement contractor(s) selected and contracted for by the School District to complete the Work and, in such event, the Surety's payment and other obligations pursuant to this Performance Bond shall not be thereby diminished or otherwise limited or modified.

Notwithstanding anything to the contrary, in the event the School District determines that the Principal has not met, or likely will be unable to meet, any deadline required pursuant to the Contract, or that Principal's performance otherwise does not conform with the requirements of the Contract, the School District may notify the Surety. In such event, the Surety must make reasonable attempts to assist the Principal to resolve or avoid the default by the Principal. The Surety and Principal expressly agree that neither the giving of such notice by the School District nor the giving of such assistance by the Surety shall be deemed or construed to constitute interference by the School District or the Surety with the Contract or the ability of the Principal to obtain any bond(s) in any amount(s) from any surety insurer(s).

For value received, the Surety hereby stipulates and agrees that this Performance Bond shall not be exonerated and the Surety shall not be released from its obligations pursuant to this Performance Bond by any change, amendment or other modification of the Contract or other Project documents, or of the Principal's rights and/or obligations pursuant thereto, and Surety hereby waives notice of any and all such modifications.

***(The remainder of this page intentionally left blank.)***

The Surety shall not be deemed to have fully and appropriately executed this Performance Bond unless Surety has provided all of the following information:

**SURETY'S SOUTHERN CALIFORNIA/LOCAL REPRESENTATIVE**

\_\_\_\_\_  
Company Name

\_\_\_\_\_  
Street Address

\_\_\_\_\_  
City, State, Zip Code

\_\_\_\_\_  
Representative Name

\_\_\_\_\_  
Representative Telephone Number

**SURETY'S REPRESENTATIVE FOR FILING CLAIMS**

\_\_\_\_\_  
Company Name

\_\_\_\_\_  
Street Address

\_\_\_\_\_  
City, State, Zip Code

\_\_\_\_\_  
Representative Name

\_\_\_\_\_  
Representative Telephone Number

***(The remainder of this page intentionally left blank.)***

Each person that signs this Performance Bond on behalf of the Principal or the Surety thereby represents and warrants that the party he or she represents has duly authorized him or her to sign, and thereby bind such party to, this Performance Bond.

**IN WITNESS WHEREOF**, the Principal and Surety have executed this Performance Bond as evidenced by the signatures below of their respective, duly authorized representatives.

**PRINCIPAL**

**SURETY**

\_\_\_\_\_  
Company Name

\_\_\_\_\_  
Company Name

\_\_\_\_\_  
Representative Signature

\_\_\_\_\_  
Representative Signature

\_\_\_\_\_  
Representative Name

\_\_\_\_\_  
Representative Name

\_\_\_\_\_  
Representative Title

\_\_\_\_\_  
Representative Title

\_\_\_\_\_  
Date Signed

\_\_\_\_\_  
Date Signed

**Principal: Attach Notary acknowledgment to this Performance Bond and, if applicable, imprint corporate seal in the space below this line.**

**Surety: Attach Notary acknowledgment and power of attorney to this Performance Bond and imprint corporate seal in the space below this line.**

## CERTIFICATION REGARDING DVBE PARTICIPATION

**District:** Solana Beach School District

**Project:** Skyline Backstop Upgrades

**Bid Package No.:** 2211

**Contractor:** \_\_\_\_\_

---

The undersigned hereby certifies to the District, subject to penalty for perjury pursuant to the laws of the State of California, that all of the following is true and correct:

- (i) The undersigned is a duly authorized representative of the Contractor and, in that capacity, has executed this certification on behalf of the Contractor;
- (ii) The California-certified DVBE entities listed on the Attachment Sheet(s) attached hereto participated in the Contract for the above-referenced Project/Bid Package(s) to the extent described on such Attachment Sheet(s); and
- (iii) The dollar amount of the DVBE participation in the Contract totaled: \_\_\_\_\_ dollars (\$ \_\_\_\_\_), which represents approximately \_\_\_\_\_ percent (\_\_\_ %) of the total Contract Amount, including any Change Orders, for the Project/Bid Package(s).

Contractor Name: \_\_\_\_\_

Representative Name: \_\_\_\_\_

Representative Title: \_\_\_\_\_

Representative Signature: \_\_\_\_\_

Date Signed: \_\_\_\_\_

**Note:** This certification page must be accompanied by the list(s) of DVBE entities prepared using the following Attachment Sheet. Make and use copies of the Attachment Sheet, as necessary to list additional DVBE entities.



# CERTIFICATION REGARDING DVBE PARTICIPATION – ATTACHMENT SHEET

**District:** Solana Beach School District

**Project:** Skyline Backstop Upgrades

**Bid Package No.:** 2211

**Contractor:** \_\_\_\_\_

---

1. DVBE Entity Name: \_\_\_\_\_

State DVBE Certification No.: \_\_\_\_\_ Telephone No.: \_\_\_\_\_

Business Address: \_\_\_\_\_

Participation in Contract: \$ \_\_\_\_\_

Type of Participation: \_\_\_\_\_

2. DVBE Entity Name: \_\_\_\_\_

State DVBE Certification No.: \_\_\_\_\_ Telephone No.: \_\_\_\_\_

Business Address: \_\_\_\_\_

Participation in Contract: \$ \_\_\_\_\_

Type of Participation: \_\_\_\_\_

3. DVBE Entity Name: \_\_\_\_\_

State DVBE Certification No.: \_\_\_\_\_ Telephone No.: \_\_\_\_\_

Business Address: \_\_\_\_\_

Participation in Contract: \$ \_\_\_\_\_

Type of Participation: \_\_\_\_\_

4. DVBE Entity Name: \_\_\_\_\_

State DVBE Certification No.: \_\_\_\_\_ Telephone No.: \_\_\_\_\_

Business Address: \_\_\_\_\_

Participation in Contract: \$ \_\_\_\_\_

Type of Participation: \_\_\_\_\_

**Note:** Types of DVBE participation may include, but are not limited to: (i) construction; (ii) architectural and/or engineering; (iii) suppliers of materials, equipment and/or supplies; and (iv) information technology.

## SPECIAL PROVISIONS

1. **Effect of Special Provisions.** These Special Provisions establish specific requirements applicable to the Work, the Project and/or the Project Site. To the extent these Special Provisions conflict with any provisions of the other Contract Documents, expressly modify the other Contract Documents, or establish requirements in addition to those set forth in the other Contract Documents, the Special Provisions shall to that extent govern over the other Contract Documents; however, the unaffected provisions of the other Contract Documents shall remain in full force and effect.

Use one of the following and delete the other.

2. **Architect.** There is no Architect for the Project.
2. **Architect.** The Architect for the Project is [Click here to enter firm name](#) and [Click here to enter individual's name](#) is the Architect of Record and primary contact for the Architect.

Use one of the following and delete the other.

3. **Construction Manager.** There is no Construction Manager for the Project.
3. **Construction Manager.** The Construction Manager for the Project is [Click here to enter firm name](#) and [Click here to enter individual's name](#) is the primary contact for the Construction Manager.
4. **Copies of Plans and Specifications.** Contractor shall be responsible for printing the sets of the Plans and Specifications that it needs for construction of the Project using the electronic copy available from the District upon request.
5. **Applicable Laws, Regulations, Ordinances, or Other Requirements.** In addition to other requirements described in the Contract Documents, the Contractor must obtain or otherwise comply with the requirements described below in this Section. For each, the Contractor must maintain on the Project Site a current copy of documentation that evidences satisfaction of such requirements. Such requirements are as follows:
  - (i) Business license issued by city or county (whichever is applicable) in which the Project Site is located.
6. **Field Office and Restroom Requirements.** The Contractor must furnish any and all necessary field offices and restrooms for the Project. The District will NOT provide field restrooms for the Project, and the Contractor's workforces will not have access to any existing restrooms at the Project Site.
7. **Dust Control.** The Contractor, at its own expense, shall undertake reasonable dust-control measures to prevent dust and other particulates attributable to the Work from leaving the Project Site, which measures shall include, but not be limited to, appropriate application of water or other approved dust palliative.

8. **Liquidated Damages.** As noted in Section 5.5 of the General Provisions, time is of the essence with respect to the Contract and Completion of the Work. The Liquidated Damages payable by the Contractor pursuant to Section 5.5 of the General Provisions shall be \$[Click here to enter amount](#) per day or portion thereof.
9. **Access to Project Site.**
- 9.1 The failure of the Contractor or any of its employees, subcontractors, materials suppliers or others connected with the Work to comply with the provisions of this Section shall be deemed a material breach of the Contract by the Contractor.
- 9.2 If the Project Site is an existing school of the District (“School”), then, except as expressly authorized by the District, none of the Contractor, its subcontractors, materials suppliers or others providing any work or services in connection with the Project shall arrive at, enter or be present on or in the vicinity of the School, and no portion of the Work shall be performed on or at the School, between the hours of 7:30 a.m. and 3:30 p.m. on any weekday (Monday through Friday, inclusive) when School is in session.
- 9.3 If the Project Site is a School, and the District has authorized exceptions to the prohibitions set forth in Subsection 9.2, above, the Contractor shall be responsible for ensuring that each of its employees, and any employees of its subcontractors, materials suppliers and others providing any work or services in connection with the Project, who arrive at the Project Site during hours when the School is in session, shall check in at the School’s administrative office before otherwise entering in and upon the Project Site. School staff shall escort all such persons to the locations on the Project Site where they are required and/or permitted to be in connection with the Work.
- 9.4 The employees of the Contractor, its subcontractors, materials suppliers and others providing any work or services in connection with the Project must enter the School grounds and travel to the Project Site using only the designated entry gate and path of travel as directed by the District. If applicable, the Contractor must sign for and obtain from the District a key for such designated gate. The Contractor must return such key (and all copies of such key) to the District upon completion of the Project.
- 9.5 At no time shall the employees or other personnel of the Contractor, its subcontractors, materials suppliers or others providing any work or services in connection with the Project be in the vicinity or in the presence of any student or students at the School unless a member of the School or District staff is also present.
10. **Employee Background Checks.** If this Section INITIALLY DOES NOT require that the Contractor comply with Section 3.7 of the General Provisions, the District reserves the right in appropriate circumstances to subsequently require that the Contractor comply with Section 3.7 of the General Provisions, including, without limitation, if the time for performance of the Work is, for

any reason, extended beyond the time initially permitted pursuant to the Contract. Section 3.7 of the General Provisions initially shall (check only one of the following):

- Be in effect or apply to the Contract.
- NOT be in effect or apply to the Contract.

11. **Contractor General Liability Insurance.** The General Liability Policy described in Section 8.1 of the General Provisions must have coverage limits of not less than \$1,000,000 combined single limit per occurrence and \$2,000,000 aggregate.

12. **Contractor Vehicle Liability Insurance.** The Vehicle Liability Policy described in Section 8.2 of the General Provisions must have coverage limits of not less than \$1,000,000 combined single limit per occurrence and \$1,000,000 aggregate. **Or insert other appropriate limits**

13. **Contractor Builder's All-Risk Insurance.** Section 8.4 of the General Provisions shall (check only one of the following):

- Be in effect or apply to the Contract.
- NOT be in effect or apply to the Contract.

14. **Subcontractor General Liability Insurance.** Each subcontractor must have general liability insurance in effect as provided in Part 8 of the General Provisions, with coverage limits of not less than \$1,000,000 combined single limit per occurrence and \$1,000,000 aggregate. **Or insert other appropriate limits**

15. **Subcontractor Vehicle Liability Insurance.** Each subcontractor must have vehicle liability insurance in effect as provided in Part 8 of the General Provisions, with coverage limits of not less than \$1,000,000 combined single limit per occurrence and \$1,000,000 aggregate. **Or insert other appropriate limits**

16. **Preconstruction Conference.** The District will (check only one of the following):

- Schedule and conduct a mandatory preconstruction conference for purposes of describing labor-law requirements.
- NOT schedule and conduct a mandatory preconstruction conference for purposes of describing labor-law requirements.

17. **DVBE Participation.** With respect to the DVBE requirements set forth in Section 10 of the Instructions for Bidders and Section 11.5 of the General Provisions, the Contractor is (check only one of the following):

Required to comply with such requirements.

NOT required to comply with such requirements.

**DVBE Advertising.** If the foregoing paragraph indicates that compliance with DVBE requirements is required, the advertisements for DVBE shall be placed by (check only one of the following):

the District

the Contractor

18. **Sole Source Items.** The District Board has found that, for reasons authorized pursuant to Public Contract Code Section 3400, the equipment, materials, and/or other things described in this Section are specified as sole-source items (each a "Sole Source Item") and the Contractor must provide the exact Sole Source Item specified, not an "equal" or substitute item. The Sole Source Items include:

19. **Retention.** The District has found in accordance with Public Contract Code Section 7201 that the Project is substantially complex, and the basis for such finding is as follows:

Based on the foregoing the District has determined that Retention shall equal (10%).

## GENERAL PROVISIONS

### **PART 1. ADMINISTRATIVE.**

**Section 1.1 Definitions.** Each capitalized term that is defined in any of the Contract Documents shall have such meaning for purposes of all of the Contract Documents, despite not being defined in any other of the Contract Documents.

**Section 1.2 Authority of District Representative.** The District Representative shall have the authority for general supervision and control of the Work and the Project. The District Representative has the authority to determine the amount, quality, acceptability and fitness of all parts of the Work, and to decide all questions pertaining to the Work, except to the extent that the Architect is responsible for answering such questions. The District Representative shall have authority to stop any or all of the Work whenever, in the District Representative's opinion, the Project or the Work is not being executed in accordance with applicable requirements or in a proper manner.

**Section 1.3 District's Inspector.** The District may contract with a DSA-approved inspector and one or more specialty inspectors (each an "Inspector") to observe and review some or all of the Work, and who will act as representatives of the District. Such observation and review by any Inspector shall not, in any way, relieve the Contractor from responsibility for full compliance with all of the terms and conditions of the Contract, nor be construed to lessen to any degree the Contractor's responsibility for providing efficient and capable supervision as required herein. The Inspectors are not authorized to make changes to the Plans, Specifications, or other Contract Documents, and no observation, review, or approval of work and/or methods by any Inspector shall be deemed or construed to relieve the Contractor of responsibility for the correction of any subsequently discovered defects.

**Section 1.4 Extra Services of District Representative or Inspector.** The Contractor and/or its surety, if applicable, shall reimburse the District in the event the District incurs any costs or expenses for services of the District Representative, an Inspector and/or the Architect in connection with: (i) enforcement of any guarantee or warranty for any portion of the Work; (ii) litigation related to or arising out of the Contract or the Work; (iii) correction of defects or poor quality workmanship in the Work; and/or (iv) completion of the Work by the surety or, if applicable, the District. The Contractor or its surety, if applicable, shall reimburse any such amounts to the District with reasonable promptness, but in no event later than sixty days after request from the District.

**Section 1.5 Separate Contracts.** The District reserves the right to award any other contract(s) in connection with the Project for work and/or services not included in the Contractor's scope of work, and the work to be completed pursuant to such contract(s) may proceed simultaneously with the execution of the Work by the Contractor. The Contractor shall coordinate its operations with those of all other contractors on the Project. The Contractor shall cooperate with the District and other contractors with respect to all aspects of the overall work necessary to complete the Project, including storage of equipment and materials. The Contractor and its subcontractors shall remain informed of the progress and the detail work of other contractors and shall immediately notify the District Representative of any reasonably apparent lack of progress or defective workmanship on the part of other contractors, as such delay or such defective workmanship may interfere with the completion of the Work. Failure of the Contractor to remain informed of the progress of work on the Project and/or failure to give notice of any reasonably apparent lack of progress or defective workmanship by others shall be deemed to be acceptance by the Contractor of that work as being satisfactory for proper coordination with the Work and to be a waiver by the Contractor of any delays arising from that work by others.

**Section 1.6 Ownership of Contract Documents.** All copies of any Contract Documents, including Plans and Specifications, for the Work and the Project are and shall remain the property of the District. The Contractor shall not use or allow the use of the Contract Documents or any portion or provision thereof in connection with any work other than the Work. With the exception of one set of the signed Contract and other Contract Documents to be retained in the Contractor's records if desired by the Contractor, all copies of all Contract Documents are to be returned to the District upon completion and acceptance of the Work.

## **PART 2. CONTRACTOR'S PERFORMANCE.**

**Section 2.1 Independent Contractor Status.** The Contractor shall, for all purposes of the Contract, be deemed to be an independent contractor. The Contractor shall not be deemed or construed to be an officer, employee, agent, consultant or representative of the District for any purpose related to the Work or the Project, except to the extent expressly authorized in writing by the District.

**Section 2.2 Standard of Performance.** The Contractor represents and warrants that it has the professional skill, knowledge, and experience necessary to perform and complete the Work within the time required pursuant to the Contract. The Contractor shall apply such skill, knowledge and experience in the completion of the Project, at a minimum level at least equal to that expected generally of professionals employed in construction of public schools within the State. The Contractor shall perform and complete the Work in accordance with standards not less than established by applicable laws, rules and regulations, industry and trade association standards, manufacturers' recommendations, and, if any, community or area standards. The Contractor represents and warrants that all of its employees and subcontractors shall have sufficient skill, knowledge, and experience to perform the Work that will be assigned to them.

**Section 2.3 Licenses.** The Contractor represents and warrants that it currently has, and that it shall maintain until completion and acceptance of the Project, any and all contractor licenses, permits, qualifications, and other approvals of whatever nature as are legally required for the Contractor to perform the Work required pursuant to the Contract and to complete the Project. The Contractor further represents and warrants that it currently has, or that, prior to commencing the Work it will obtain, any and all business licenses that must be obtained from any local governmental entities. This Section shall be deemed and construed to relate to authorizations of the Contractor, and not authorizations of the Work, which are covered by Sections 5.1 and 5.2 of these General Provisions.

**Section 2.4 Solicitation of Contract.** The Contractor hereby represents and warrants that it has not employed or retained any company or person, other than a bona fide employee working solely for the Contractor or its subcontractor(s), to solicit or secure the Contract on behalf of the Contractor. The Contractor also hereby represents and warrants that it has not paid, and has not agreed to pay, any company or person, other than a bona fide employee working solely for the Contractor or its subcontractor(s), any fee, commission, percentage, brokerage fee, gift or other consideration that is or was contingent upon the award of the Contract to the Contractor. Breach or violation of these representations and warranties shall result in the District having the right to terminate the Contract without further obligation or liability to the Contractor.

**Section 2.5 Conflicts of Interest.** The Contractor represents and warrants that, except as provided by the Contract, it shall not give, accept, encourage or solicit any payment or other thing to or

from any District Board member, officer or employee of the District, or otherwise do any act(s) that may result in any such person having a conflict of interests contrary to applicable federal, state, or local law.

**Section 2.6 Project Records.** The Contractor shall maintain all documents, books, papers, accounting records, computer files, and other information related to the Project and performance of the Work (“Project Records”), including, but not limited to, the Contract, the Plans and Specifications, Change Orders, submittals, cut-sheets, requests for information, daily reports, correspondence, permits, insurance policies, Certificates of Insurance, testing and inspection reports, the costs of administering the Contract, and safety records. The Contractor shall keep such accurate and comprehensive Project Records as are: (i) necessary for proper administration and performance of the Work; and (ii) required by law or the Contract. All Project Records, as applicable, shall be maintained in accordance with generally accepted accounting principles. In accordance with Government Code Section 8546.7, the State has the right to examine, review, audit and/or copy the Project Records during the three-year period following final payment to the Contractor pursuant to the Contract. In addition, the District, DSA, SAB and OPSC each hereby has the right to examine, review, audit and/or copy the Project Records during the four-year period following final payment to the Contractor pursuant to the Contract. Therefore, the Contractor shall make the Project Records available at its offices at all reasonable times during the performance of the Work and for four years from the date of final completion or filing of a Notice of Completion for the Project, whichever is later. However, if any audit is commenced within such four-year period, the Contractor shall make the Project Records available at all reasonable times until proceedings related to such audit are complete and all statutes of limitation related thereto have expired. In the event the District notifies the Contractor that federal funds have been used in connection with the Project, the Contractor shall retain and make available the Project Records for such longer period as may be required by federal law.

**Section 2.7 Damages Incurred by District Pursuant to Other Contracts.** Notwithstanding anything to the contrary, if the District is required, pursuant to any other contract entered into by the District in connection with the Project, to pay any damages (whether liquidated pursuant to such other contract or otherwise) and/or costs (whether fixed by a court of competent jurisdiction or otherwise), and the District would not have been responsible for such damages and/or costs but for an act or omission for which the Contractor is responsible, then the District may seek indemnification from the Contractor pursuant to Part 8 of these General Provisions and/or may pursue such other remedies as are permitted by law and/or the Contract.

### **PART 3. EMPLOYEES AND SUBCONTRACTORS.**

**Section 3.1 Job Superintendent.** The Contractor shall have present on the Project Site at all times during the course of the Work an experienced and competent superintendent and any necessary assistants, all satisfactory to the District, who shall supervise the Work and the Contractor’s employees and subcontractors on the Project. The job superintendent shall not be changed except with the written consent of the District, unless the Contractor determines that the job superintendent’s performance is unsatisfactory or in the event the job superintendent is no longer employed by the Contractor. If the District determines that the performance of any job superintendent or assistant is, for any reason, not satisfactory, the Contractor must promptly replace the job superintendent or assistant with someone reasonably acceptable to the District. The Contractor shall not thereafter suffer or permit any such person to perform any of the Work or to be present on or at the Project Site. The job superintendent shall represent the Contractor and all instructions given to the job superintendent shall be as binding on the Contractor as if given to the owner(s) or other primary representative(s) of the Contractor. Upon



request of the District, the Contractor shall confirm in writing to the District any oral instructions given to the Contractor through its job superintendent.

**Section 3.2 Contractor's Employees.** The employees of the Contractor shall at all times be under the Contractor's exclusive direction and control with respect to the Project. The Contractor shall pay all wages, salaries, and other amounts due to such personnel in connection with their performance of the Work, as required by law. Contractor shall be responsible for all reports and obligations respecting such personnel, including, but not limited to: social security taxes, federal and state income tax withholdings, unemployment insurance, and workers' compensation insurance. The Contractor shall employ only competent workers for execution of the Work and shall not employ any person who is unfit or unskilled in the work assigned to him or her. The Contractor shall at all times enforce strict discipline and good order among its employees and any and all subcontractors' employees performing any portions of the Work. The Contractor shall supervise and control its employees and all subcontractors' employees performing any portions of the Work to ensure adequate performance and discipline. The Contractor shall immediately remove from the Project and Project Site any person, regardless of whether employed by the Contractor or any subcontractor, who is determined by the District to be uncooperative, incompetent, or a threat to the safety of persons or the Work, or who fails or refuses to perform the Work in a manner consistent with the requirements of the Contract Documents. The Contractor shall not thereafter suffer or permit any such person to perform any of the Work or to be present on or at the Project Site.

**Section 3.3 Prohibition Against Unlawful Discrimination.** The Contractor represents and warrants that it is an equal opportunity employer and it shall not discriminate in violation of any applicable federal, State, or other law, rule, regulation, or governmental requirement, including, but not limited to discrimination against any employee or applicant for employment on account of such person's race, religion, color, national origin, ancestry, sex, or age. The Contractor must apply such policy of non-discrimination in connection with all activities related to initial employment, promotion, demotion, transfer, recruitment or recruitment advertising, layoff or termination of Contractor's employees or any subcontractors.

**Section 3.4 Subletting and Subcontracting Fair Practices Act.** The Contractor shall comply with all provisions of the "Subletting and Subcontracting Fair Practices Act" set forth at Public Contract Code Section 4100 *et seq.* The Contractor shall not subcontract any portion of the Work except as indicated in its Bid Proposal. If the Contractor failed to identify in its Bid Proposal a subcontractor for any portion of the Work in excess of one-half of one percent of its total bid, or if the Contractor identified more than one subcontractor for the same portion of work to be performed pursuant to the Contract, the Contractor agrees that it is fully qualified to perform, and the Contractor shall perform, that portion of the Work with its own forces, not by using any subcontractor(s).

**Section 3.5 Responsibility for Subcontractors.** The Contractor shall be responsible for any and all acts, errors, and omissions of its subcontractors performing any work or services in connection with the Project. The Contractor shall also be responsible for ensuring that all portions of the Work performed by its subcontractors conform with all requirements of the Contract Documents and applicable law. The Contractor shall immediately remove from the Project and Project Site any subcontractor that the District determines is uncooperative, incompetent, or a threat to the safety of persons or the Work, or that fails or refuses to perform the Work in a manner consistent with the requirements of the Contract Documents. The Contractor shall not thereafter suffer or permit any such subcontractor or any of its employees to perform any of the Work or to be present on or at the Project Site.

**Section 3.6 Subcontractor Insurance.** The Contractor shall ensure and verify that its subcontractors obtain and maintain all necessary liability and other insurance as required pursuant to the Contract Documents and/or by law.

**Section 3.7 Procedures to Prevent Contact with Students.**

**Subsection 3.7.1 Significance of Requirements.** This Section shall be applicable to the Contract if so specified in the Special Provisions. If applicable, the District has determined that persons assigned to the Work or who otherwise will be present at, on or in the vicinity of the Project Site on account of the Work may have more than “limited contact” with minor-aged students.

**Subsection 3.7.2 Employee Background Checks.** The Contractor, consistent with Education Code Section 45125.1, shall require and be responsible for ensuring that each person who will be at, on or in the vicinity of the Project Site on account of the Work shall comply with all California Department of Justice guidelines and requirements relating to fingerprinting and criminal-history background checks. The Contractor shall certify in writing to the District, using the “Certification Regarding Employee Background Checks” form, which is one of the Required Contract Forms, that no person assigned to the Work or who otherwise will be present at or on the Project Site has been convicted of any serious or violent felonies (as described in Education Code Section 45122.1). The Contractor must attach to the executed Employee Background Check Certification form a list of all persons to whom the certification applies. The Contractor shall prohibit and prevent each and every person who will be at, on or in the vicinity of the Project Site on account of the Work (including not only all persons assigned to the Work directly by the Contractor, but also all persons assigned to the Work by any subcontractor, materialman, or other person or entity that furnishes any labor, materials, services, goods or other things in connection with the Work) from being present at, on or in the vicinity of the Project Site unless and until the Contractor provides the required certification including such person to the District.

**Subsection 3.7.3 Responsibility for Subcontractor Compliance.** The Contractor shall require in each of its subcontracts that, if the subcontractor will assign any person to the Work or otherwise will cause or permit any person to be present at or on the Project Site, the subcontractor must cooperate in regard to, and fully comply with, the requirements of this Section 3.7. The Contractor may on that basis delegate responsibility for compliance with this Section 3.7 to any such subcontractor; however, the Contractor at all times retains full responsibility and/or liability for such compliance or lack thereof.

**Subsection 3.7.4 Alternatives to Background Checks.** Upon request of the Contractor with respect to any particular situation and/or duration of time, the District in its sole discretion may consent to the Contractor implementing measures intended to protect the District’s minor-aged students, which measures would be in lieu of the Contractor complying with Subsections 3.7.2 and 3.7.3 herein. Subject to District approval, such alternative measures might include, but are not necessarily limited to: (i) installing a physical barrier to limit contact between students and the employees and other representatives of the Contractor, subcontractors, and others present on or at the Project Site on account of the Work; (ii) providing for the continuous supervision and monitoring of such employees, representatives and others by an employee of the Contractor who has received fingerprint clearance from the California Department of Justice; or (iii) providing for the surveillance of such employees, representatives and others by a District employee. The Contractor must implement any such approved alternative measures at no additional cost to the District, and the Contractor shall be responsible for ensuring compliance with such alternative measures by or with respect to all persons assigned to the

Work or who otherwise will be present at, on or in the vicinity of the Project Site on account of the Work.

**Subsection 3.7.5 Consequences of Non-Compliance with Requirements.** Due to the possible adverse consequences of contact with students and other minor-aged individuals, any failure by the Contractor to ensure compliance with the requirements of this Section 3.7 shall be deemed and construed to constitute a material breach of the Contract, upon which the District, in its sole discretion, may immediately terminate the Contract without any further compensation to Contractor and/or pursue all other rights and remedies it may have against the Contractor pursuant to law or the Contract.

#### **PART 4. PLANS AND SPECIFICATIONS.**

**Section 4.1 Errors, Inconsistencies, and/or Omissions in Contract Documents.** The Contractor shall carefully study and compare all of the Contract Documents and requirements therein, and be adequately familiar with the same as the Work commences and progresses. The Contractor shall immediately, upon discovery, inform the District Representative in writing of any error, inconsistency, omission, or other discrepancy in the Contract Documents. The District will notify the Architect of any such error, inconsistency, omission, or discrepancy. The Architect shall promptly investigate and/or verify the same. Unless and until authorized by the District, any of the Work affected by any such error, inconsistency, or omission that is performed by Contractor shall be at the Contractor's risk and/or cost.

**Section 4.2 Conflict Between Plans and Specifications.** In the event of any conflict between the requirements of the Plans and the requirements of the Specifications, the Plans shall govern with respect to matters of quantity, and the Specifications shall govern with respect to matters of quality. In the event of any conflict within such Plans involving quantities, or within such Specifications involving qualities, the Contractor shall furnish the greater quantity and/or the higher quality, unless otherwise directed by the District Representative and/or Architect.

**Section 4.3 Titles and Headings in Contract Documents.** The titles and/or headings of the sections, divisions and paragraphs set forth in the technical specifications, if any, are provided for convenience only and shall not be deemed or construed as a correct or complete segregation of the several units of material and labor. No responsibility, either direct or implied, will be assumed by the District for errors, omissions or duplications by the Contractor or its subcontractors, resulting from actual or alleged error in the arrangement or order of the provisions set forth in the Contract Documents.

#### **Section 4.4 Shop Drawings.**

**Subsection 4.4.1 Advance Approval Required.** The Contractor must, in accordance with the procedures set forth in this Section, submit for the approval of the Architect all shop and setting drawings, samples, and other submittals (each a "Shop Drawing") required pursuant to the Contract Documents or that are requested by the Architect. If the Contractor completes any portion of the Work included in or affected by the subject matter of any Shop Drawing prior to receipt of the Architect's approval of such Shop Drawing, all such Work shall be at Contractor's own risk.

**Subsection 4.4.2 Copies Required.** Unless otherwise specified in the Contract Documents or by the Architect, the Contractor must submit six sets of all Shop Drawings, together with a letter of transmittal listing the numbers and dates of the Shop Drawings and/or other information submitted to the Architect. Any such Shop Drawings shall be complete in every respect and, where more than a single page, bound in sets.

**Subsection 4.4.3 Timely Submittal.** The Contractor must submit each and all Shop Drawings in a timely manner, with adequate consideration given to construction scheduling requirements so as to allow ample time for checking, correcting, resubmitting, and rechecking of any Shop Drawing by the Architect.

**Subsection 4.4.4 Review and Approval in Advance by the Contractor.** The Contractor must review each Shop Drawing prior to submittal to the Architect, including, without limitation, for conformance with all requirements of the Contract Documents. All Shop Drawings submitted for approval by the Architect must be marked with the name of the Project, numbered consecutively, and bear the stamp of approval or signature of the Contractor as evidence that the Contractor has reviewed and approved the Shop Drawings. The Architect will not accept or review Shop Drawings that do not bear the Contractor's stamp of approval or signature, and shall return such Shop Drawings to the Contractor for re-submission.

**Subsection 4.4.5 Identifying Variations from Contract Requirements.** If, for any reason, any Shop Drawing varies from the requirements of the Contract Documents, the Contractor must specifically identify the variation, by "clouding" or other method that makes the variation apparent, and the Contractor must explain such variation in the letter of transmittal. Absent the Contractor so identifying and explaining a variation from the requirements of the Contract Documents, the Contractor shall not be relieved of the responsibility for performance of the Work in accordance with the Contract Documents, regardless of the fact that the Architect may have approved the applicable Shop Drawing.

**Subsection 4.4.6 Approval of Variations from Contract Requirements.** Subject to the Contractor's compliance with Subsection 4.4.5, above, the Architect may approve any Shop Drawing that varies from the requirements of the Contract Documents if such variation: (i) does not require a change in the Contract Amount or time for performance of the Work; (ii) does not affect the longevity, use or maintenance of the completed Work; and (iii) approval would be in the District's best interests.

**Subsection 4.4.7 Interpretation of Architect Approval.** Architect approval of Shop Drawings shall be deemed a "general" approval and, except as otherwise provided in Subsection 4.4.6, above, shall not be construed: (i) to permit any variation between the Work as performed and the requirements of the Contract Documents; (ii) to relieve the Contractor of responsibility for any error(s) that may exist in the details, dimensions, or other information set forth in any Shop Drawing; or (iii) as approval of variations between the Work as performed and details or instructions for the Work previously provided to the Contractor by the District Representative.

**Section 4.5 Interpretation of Documents.** The District Representative or Architect shall resolve all questions related to the interpretation of the Contract Documents or the workmanship, scope, value or other matters related to the Work performed or to be performed thereunder, and the adjustment determined by Architect, if any, shall be conclusive subject to the approval of the District.

## **PART 5. WORK AND SITE CONDITIONS.**

**Section 5.1 Work Permits and Licenses.** Except as provided in Section 5.2 of these General Provisions, the Contractor shall obtain, at its own expense, any and all permits, licenses and other authorizations necessary for the performance of the Work, including, but not limited to, any required

construction permits, Cal-OSHA safety-related permits, storm water permits, and utility-connection permits.

**Section 5.2 Building Permits and Permanent Utility Connections.** Notwithstanding Section 5.1 of these General Provisions, the District shall procure and pay for any and all building permits and permits for permanent utility connections that must be obtained from the DSA, local building officials or utility company, to the extent required by law or obtained by the District in its discretion. Except for the initial building permit, the Contractor must give written notice to the District a reasonable amount of time in advance of when any such permit will be required, to prevent any associated delays in the performance of the Work or completion of the Project.

**Section 5.3 Construction Schedule.** During the preconstruction meeting shown on the Master Schedule, the Contractor shall submit to the District Representative for review a schedule for completion of the Work and all major components thereof, which shall include the “critical path” for such Work and shall be consistent with the Work of any other contractors on the Project and the Master Schedule. The District Representative may reject the construction schedule as unreasonable or inconsistent with the Master Schedule, in which case the Contractor shall revise and resubmit the construction schedule. Upon acceptance of the construction schedule by the District Representative, the construction schedule shall be incorporated into the Master Schedule. The Contractor shall ensure that its employees and subcontractors are aware of and comply with the approved Master Schedule. Acceptance of a construction schedule by the District Representative shall not be construed as verifying or approving the logic or feasibility of the schedule. The Contractor shall at all times comply with the Master Schedule. In the event the Work falls behind schedule, the Contractor shall, within twenty-four hours of any request by the District, prepare and provide to the District a recovery schedule indicating the actions to be taken and the Work to be performed in order to bring the actual work performed into compliance with schedule requirements. Upon approval of the recovery schedule by the District, the Contractor must perform the Work in accordance with the recovery schedule to ensure conformance with the Master Schedule. Any float in the Master Schedule shall be for the benefit of the Project, as determined by the District Representative, not for the benefit of the Contractor, any other prime contractor, or any of their subcontractors.

**Section 5.4 Manpower Requirements.** At any time during the period for completion of the Work, the District may determine in its reasonable discretion that the Contractor or any of its subcontractors is not employing sufficient manpower on the Work to reasonably complete the Work or any component thereof within the scheduled amount of time. In such event, within forty-eight hours of any request by the District, the Contractor shall provide such additional manpower, or shall ensure that the subcontractor provides such additional manpower, as the District determines is necessary to ensure completion of the Work in a timely manner. Any failure by the Contractor or subcontractor upon the District’s request to provide such additional manpower as is required by the District shall constitute grounds for termination of the Contractor and/or the subcontractor. As an alternative to termination, the District, in its sole discretion, may determine to supplement the workforce of the Contractor or the subcontractor in order to ensure timely completion of the Work, and the cost thereof shall be deducted from amounts due to the Contractor pursuant to the Contract, and no such action by the District shall be deemed or construed to constitute interference by the District with the Contract or the Contractor’s right to perform the Work.

**Section 5.5 Liquidated Damages.** Time is of the essence with respect to the Contract and completion of the Work. The Parties acknowledge and agree that the District will suffer damages if Contractor does not complete the Work within the time provided pursuant to the Contract. Because it is impractical and infeasible to determine the actual amount of damages the District will incur, in

accordance with Government Code Section 53069.85, the Contractor shall pay to the District liquidated damages at the rate specified in the Special Provisions for each and every calendar day, or portion thereof if not a full day, that the Work remains uncompleted and not accepted by the District after the time provided pursuant to the Contract, as such time may be modified in accordance with the Contract (“Liquidated Damages”). Liquidated Damages shall constitute compensation to the District for Contractor’s delay or delay caused by its subcontractors, suppliers, *et cetera*, in completion of the Work and shall not be construed as a penalty or forfeiture of any other right or remedy under the Contract or law. In the event the Contractor fails to pay any such Liquidated Damages, the District may deduct such amount(s) from any payments due (or that may become due) to Contractor pursuant to the Contract. Nothing in this Section shall be deemed or construed to preclude the District from recovering other or additional damages, as provided by the Contract or applicable law, attributable to any breach or default by the Contractor of its obligations pursuant to the Contract.

**Section 5.6 Extension of Time.** Subject to the other provisions of this Section, District shall extend the time for completion of the Work, by such number of days determined by the District in its reasonable discretion, in the event Contractor’s progress on the Work is delayed as a result of: (i) an unreasonable act or omission of the District, not contemplated by the District and the Contractor; (ii) an act or omission of any other prime contractor on the Project not consistent with the Contract Documents; (iii) Changes in the Work required by the District for reasons other than those caused by, or the fault of, the Contractor; (iv) strike or lockout not instigated by the Contractor or an affected subcontractor; (v) unusual and severe interruption in interstate or intrastate, but not local or regional, transportation; (vi) earthquake, flood, or other unavoidable casualty that is not the fault of Contractor or a result of Contractor’s actions or work; or (vii) any other cause determined by the District to justify an extension of time. As a condition precedent to the District’s obligation to grant any such extension of time, the Contractor must provide written notice of the delay to the District within five calendar days of when the delay commenced. No extension of time shall be granted for delay occurring more than five days prior to when the notice of delay is submitted in writing to the District. In the case of a continuing cause of delay, only one notice shall be necessary, but the Contractor must apprise the District on a regular basis (not less than once per week) as to the status of the delay and, also, at such time as the cause of the delay has been resolved and the affected portion of the Work has resumed. The purpose of the notice requirements of this Section are to ensure that the District has an opportunity at the earliest possible time to mitigate and resolve delays in the Project.

**Section 5.7 Workmanship and Materials.** The Contractor shall employ nothing less than good quality workmanship in performing the Work. All materials, equipment and other items incorporated into the Work shall be of good quality and, unless specified otherwise, shall be new. The Contractor shall, upon request, provide satisfactory evidence as to the type and quality of materials used in connection with the Work. If the Contractor determines that the materials delivered to the Project Site do not represent a good quality product, it shall advise the District Representative, and shall remedy the deficient quality as quickly as possible with the shortest delay, if any, to the Work on the Project, unless otherwise instructed by the District Representative.

**Section 5.8 Substitutions of Materials and Equipment.** The Contractor shall use and/or incorporate into the Work on the Project all materials and equipment as are specified in the Contract Documents, except upon approval by the District Representative or Architect of the substitution of “equal” materials or equipment. No substitutions shall be accepted unless and until the Contractor requests and receives permission in writing from the District Representative or Architect. All requests for substitution shall be made concurrently to the District, the District Representative and the Architect. The Contractor must have submitted any requests for substitution and all information in substantiation of such request not later than twenty-four hours after the date and time scheduled for opening of bids.

Notwithstanding the foregoing, the Contractor may submit a request for substitution after such deadline in the event a Specified Item has become commercially unavailable, i.e., is no longer manufactured or is available only for a manifestly unreasonable price. In connection with any such request, the Contractor shall present complete details of the “equal” item, with specific explanations of the characteristics of the details that differ from the specifications. The Contractor must expressly describe how a substitute item will differ from the Specified Item, including without limitation, compliance with applicable building and other codes, and the Contractor shall to that extent be responsible for compliance with all specifications, codes, *et cetera*, regardless of any District or Architect approval of the substitution request. The District Representative and/or Architect for the Project shall investigate the characteristics of the proposed “equal” item and the merits of the proposed substitution, and shall notify the Contractor of the determination. The determination of the District Representative or Architect as to whether a proposed substitute material, equipment, or other item is “equal” shall be final.

**Section 5.9 Contractor’s Title to Materials.** Neither the Contractor nor any subcontractor on the Project shall purchase materials, equipment, supplies or other items for use on, or incorporation into, the Work subject to any chattel mortgage or under a conditional sale or other agreement pursuant to which an interest is retained by the seller. The Contractor represents and warrants that it shall have good, free and clear title to all materials, equipment, supplies, or other items for which the Contractor accepts any payment from the District.

**Section 5.10 Tests and Inspections.** Materials, fabrication, and erection shall be tested and inspected as required by Title 21 of the California Code of Regulations and when required by the District Representative or Inspector. The cost of all such tests and inspections shall be paid by the District, except that the Contractor shall reimburse the District for (or compensation to the Contractor shall be reduced by an amount equal to) the costs of retests or re-inspections of Construction, materials, equipment and other components of the Work that prove to be defective, inadequate, or inconsistent with the requirements of the Contract Documents.

**Section 5.11 Materials Testing.** The Contractor shall deliver to the District Representative upon request, without charge to the District, and properly marked for identification purposes, all material test samples or specimens that are required pursuant to the Contract Documents. The Contractor shall pay all costs incurred in preparing, wrapping, protecting, transporting and/or mailing of required samples or specimens.

**Section 5.12 Inspection of Manufactured Items.** The Contractor must ensure that the District shall at all reasonable times have access to all places where materials, equipment, machinery, or other items for incorporation into the Work are being manufactured, produced, or fabricated for use on or incorporation into the Project. The District shall be permitted such access as will allow a determination regarding whether such materials, equipment, machinery or other items are being manufactured in strict accordance with the Contract Documents. The Contractor shall, upon request, provide the District Representative with access to all invoices, bills of lading, *et cetera*, and shall provide scales for, and/or other equipment and assistance with, weighing, measuring, or otherwise evaluating any of the materials.

**Section 5.13 Surveys.** The District, if reasonably required, will establish the boundary lines of the Project Site and all easements thereon. The Contractor shall preserve all existing bench marks and property or survey stakes, markers, or monuments as they exist in the field. The Contractor shall be responsible for each disturbance, removal or covering of any such bench marks, stakes, markers or monuments, and shall reimburse to the District (or compensation to the Contractor shall be reduced by the amount of) the actual cost and expenses incurred in restoring or replacing the same.

**Section 5.14 Access to Work.** The District, including, without limitation, the Architect, District Representative and Inspector, shall at all times and for any purpose have unrestricted access to the Work on the Project, including any areas used by the Contractor or its subcontractor(s). Each public authority with jurisdiction over the Project shall at all times have unrestricted access to the Work on the Project, including any areas used by the Contractor or its subcontractor(s), for purposes within that public authority's jurisdiction. The Contractor shall not impede or frustrate any access to or inspection of the Work, including inspection of the materials and the workmanship used in connection with the Work. The Contractor shall take all reasonable steps to facilitate any such access or inspection of the Work, including providing any equipment or other accommodations necessary or convenient for such access or inspection.

**Section 5.15 Testing and Inspection of Work.** Testing and inspection of portions or elements of the Work, or of materials, equipment or other items to be incorporated into the Work, will be required pursuant to the Contract Documents, Inspector's instructions, applicable laws, ordinances and regulations, or by public authorities. The Contractor shall give the Inspector written notice of its readiness for any such testing or inspection at least forty-eight hours prior to when the inspection is scheduled to occur. If the inspection is to be conducted by a public authority or person other than the Inspector, the notice to the Inspector shall also specify the date and time at which such inspection is to occur. If the Contractor, without prior approval, covers or renders inaccessible the portion or element of the Work, or the material, equipment or other item, that is to be tested or inspected, the Contractor, at its own expense and upon request of the Inspector, shall remove or demolish all portions of the Work as are necessary to facilitate such testing or inspection. The Contractor must give notice of any cancellation of a scheduled inspection at least twenty-four hours prior to when the inspection is scheduled to occur.

**Section 5.16 Protection of Work.** The Contractor and its subcontractor(s) shall protect the Work and any portions of the Project affected thereby from harm and are responsible under all circumstances for the conditions thereof until final acceptance of the Project by the District. The Contractor and its subcontractor(s) shall protect adjacent property from injury or damage arising out of Contractor's performance of the Work on the Project and shall repair or pay the cost of repairing any such damage or injury that occurs.

**Section 5.17 Protection of Project Site.** The Contractor shall protect all structures, walks, pipelines, utilities, trees, shrubbery, furniture, and all other items on and in the vicinity of the Project Site that may possibly be damaged or otherwise adversely affected during the performance of the Work.

**Section 5.18 Damages to Other Contractors.** In the event any other contractor or subcontractor working on the Project incurs damage(s) as a result of any act or omission of the Contractor or its subcontractor(s) that is unreasonable or not consistent with the Contract Documents, the Contractor shall make good-faith efforts to effect a settlement with the other contractor. If no such settlement is reached, and if any party commences an action or other proceeding against the District related thereto, the Contractor shall indemnify, defend and hold-harmless the District in accordance with Section 8.15 of these General Provisions.

**Section 5.19 Cleanup and Storage.** The Contractor shall ensure that the area of the Project Site in which the Work occurs is at all times, including nights and weekends, free of loose or accessible waste, materials, tools, and equipment. The Contractor shall maintain the area of the Work and the Project, including grounds and sidewalks, in a safe, neat, and clean manner that will cause the least inconvenience to the District and, as applicable, the general public, school staff, and students. The



Contractor shall comply with all instructions from the District Representative with respect to conditions at the Project Site, including, without limitation, instructions regarding removal of rubbish and debris generated by, and any unnecessary materials, tools, equipment or temporary structures owned or used by, the Contractor or its subcontractors. In the event the Contractor fails to comply with any such instruction, the District Representative may arrange for removal and the Contractor shall pay to the District (or the Contractor's compensation shall be reduced by the amount of) the actual costs of such removal. Storage of materials on the Project Site shall be under the supervision of the District Representative, but at the expense, if any, of the Contractor.

**Section 5.20 Safety.** Contractor shall perform and maintain the Work so as to avoid injury or damage to any person, including, without limitation, District employees, students, visitors and others, or to any property. In carrying out the Work, the Contractor and its employees and subcontractors shall at all times be in compliance with all applicable local, State and federal laws, rules and regulations, and shall exercise all necessary precautions for the safety of employees appropriate to the nature of the Work and the conditions under which the Work is to be performed. Required safety precautions may include, but are not necessarily limited to: (i) adequate life protection and lifesaving equipment; (ii) adequate illumination for underground and night operations; (iii) instructions in accident prevention for all employees, such as machinery guards, safe walkways, scaffolds, ladders, bridges, gang planks, confined space procedures, trenching and shoring, fall protection and other safety devices; (iv) equipment and wearing apparel as are necessary or lawfully required to prevent accidents or injuries; and (v) adequate facilities for the proper inspection and maintenance of all safety measures. The Contractor shall take steps to ensure compliance with all safety measures applicable in particular operations or kinds of work, including sufficient safeguards, such as railings, temporary walks, lights, *et cetera*, as are necessary to prevent injuries or damage to any person or property. The Contractor shall be responsible in the event of any such injury or damage resulted from any unsafe or unprotected condition on the Project that the Contractor is hereby required to protect against. The Contractor shall conduct such clean-ups of the area of the Work, including grounds and sidewalks, as are necessary to maintain the safety of the area of the Work, but in any event not less than once daily. In the event of an emergency in which life or property are endangered, the Contractor shall take all reasonable actions to safeguard such life or property. The Contractor shall require that the job superintendent or others immediately call "911" each time a medical or other emergency occurs on or at the Project Site.

**Section 5.21 Loss and Damage.** Until such time as the Work is fully complete and accepted by the District, the Contractor shall be responsible for all losses and/or repair of all damages that may arise from or be a result of: (i) the nature of the Work agreed to herein; (ii) the action of the elements or environment; or (iii) any unforeseen difficulties that may arise or be encountered during the process of completing the Work. However, provided that the Work has been constructed in strict accordance with the Contract Documents, the Contractor shall only be responsible for damage proximately caused by Acts of God (as defined in Public Contract Code Section 7105) up to a maximum of five percent of the Contract Amount. In the event any such Act of God proximately causes damages in excess of five percent of the Contract Amount, the District may, in its sole discretion, terminate the Contract effective three days following written notice to Contractor.

**Section 5.22 Regional Notification Center.** If the Work involves any trenching, boring, tunneling, digging or other excavation, the Contractor shall be solely responsible and liable for compliance with all applicable requirements of Government Code Sections 4216 through 4216.9, and with all requirements of the Contractors State License Board relating to such Government Code provisions. The Contractor must, as required, obtain from the Regional Notification Center an Underground Service Alert identification number and must provide such identification number to the

District. Prior to it expiring, the Contractor must contact the Regional Notification Center for any necessary revalidation of the identification number.

**Section 5.23 Utility Removal, Relocation and Protection.** In accordance with Government Code Section 4215, the District shall compensate the Contractor if the Plans and Specifications fail to identify any utility main- and trunk-lines on the Project Site and such failure results in additional costs to the Contractor related to: (i) locating and repairing damage to underground utility facilities not caused by the failure of the Contractor to exercise reasonable care; (ii) removing or relocating underground utility facilities not indicated in the Plans and Specifications with reasonable accuracy; and (iii) equipment necessarily idled during such work. The Contractor shall not be assessed Liquidated Damages for the delay caused by the failure of District or the owner of the utility to provide for removal or relocation of such utility facilities. The Contractor shall immediately provide written notice to the District if, during the course of the Work, the Contractor discovers utility facilities not identified in the Plans and Specifications.

**Section 5.24 Trench Excavation.** This Section shall apply to the Contract only if the Contract Amount exceeds \$25,000 and the Work requires or involves excavation of any trench or trenches five feet or more in depth. The Contractor, in conformance with Labor Code Section 6705 and other applicable law, and prior to any such excavation, shall submit to the District for review and approval a detailed plan showing the design of shoring, bracing, sloping, or other provisions to be made for worker protection from the hazard of caving ground during the excavation of such trench or trenches. The plan must be prepared by a registered civil or structural engineer and if the plan varies from the requirements of applicable Cal-OSHA Construction Safety Orders, the Contractor must obtain Cal-OSHA approval of the plan. Nothing in this Section, and no District or other approval of any plan prepared pursuant to this Section, shall relieve the Contractor of any responsibility, or result in District liability for hazards resulting from excavations performed by the Contractor.

**Section 5.25 Subsurface Conditions.** In accordance with Public Contract Code Section 7104, if the Work involves digging trenches or other excavations that extend deeper than four feet below the surface, the Contractor shall promptly, and before the following conditions are disturbed, provide written notice to the District of any: (i) material that the Contractor believes may be material that is hazardous waste, as defined in Section 25117 of the Health and Safety Code, that is required to be removed to a Class I, Class II, or Class III disposal site in accordance with provisions of existing law; (ii) subsurface or latent physical conditions at the Project Site differing from those indicated by information about the Project Site made available to bidders prior to the deadline for submitting bids; or (iii) unknown physical conditions at the Project Site of any unusual nature, different materially from those ordinarily encountered and generally recognized as inherent in the work of the character provided for in the Contract. The District shall promptly investigate any such reported condition and, if warranted, shall issue a Change Order to the Contractor for any extra work or cost not covered by the Contract. In the event of any dispute between the District and the Contractor related to any such condition, the Contractor shall continue with the Work and shall not be excused from completing the Work within the time required pursuant to the Contract Documents; however, the Contractor shall retain any and all rights provided either by contract or by law which pertain to the resolution of disputes and protests between the Parties.

**Section 5.26 Asbestos or Other Hazardous Materials.** In the event the Contractor encounters on the Project Site any material that Contractor reasonably believes to be asbestos, polychlorinated biphenyl (PCB), any material listed by the federal or State EPA or federal or State health agencies as a hazardous material, or any other material defined as being hazardous under federal or State laws, rules or regulations (“Hazardous Material”) that has not been rendered harmless, Contractor

shall immediately stop all Work in the area affected and report the condition to the District in writing. The Contractor shall resume the Work only if it is determined that no Hazardous Material is present or that such Hazardous Material has been rendered harmless. The District shall not require that the Contractor perform any Work relating to Hazardous Material without the Contractor's consent.

**Section 5.27 Certification Regarding Asbestos.** Prior to commencing the Work, the Contractor shall execute and submit to the District the "Certification Regarding Asbestos" form included in the Required Contract Forms.

**Section 5.28 Notice and Certification Regarding Lead-Containing Materials.** Pursuant to the Lead-Safe Schools Protection Act (Education Code Section 32240 *et seq.*) and other applicable law, no lead-containing or lead-based paint, plumbing or solders, or other potential sources of lead contamination, shall be used in connection with the construction of the Project, and only trained and State-certified inspectors/assessors, monitors, designers, supervisors, and workers may provide lead-related construction services. Prior to commencing the Work, the Contractor shall execute and submit to the District the "Notice and Certification Regarding Lead-Free Materials" form included in the Required Contract Forms for purposes of acknowledging Contractor's awareness and understanding of these requirements.

**Section 5.29 Inspection of Completed Work.** In addition to any testing and inspection required by the Contract Documents, the Inspector may require special inspection of any portion of the Work already completed as to which there is a reasonable question as to whether it was completed in accordance with the requirements of the Contract Documents. In such event, the Contractor shall remove or undo all portions of the Work as are necessary to facilitate inspection of the questioned portion of the Work. If the questioned portion of the Work is found not to conform with the Contract Documents, the Contractor shall pay all costs of the re-examination and correction of the Work, including repair or replacement of previously completed Work that was removed or undone to permit the inspection. If the questioned Work is found to conform with the Contract Documents, the District shall pay the cost of the re-examination and any repair or replacement of previously completed Work that was removed or undone to permit the inspection.

**Section 5.30 Correction of Work Before Final Payment.** The Contractor shall promptly remove from the Project and the Project Site all materials, equipment or other items that, as determined by the Inspector, fail to conform to the requirements of the Contract Documents, regardless of whether such materials have already been incorporated into the Work. The Contractor shall, at its own expense, promptly replace any such materials, equipment, or items with conforming materials, equipment or items, and shall thereafter repair the Work and/or execute the remaining Work in conformance with the Contract Documents. In addition, the Contractor shall bear all costs and expenses of replacing or repairing the work of other contractors or subcontractor(s) that is destroyed or damaged in the course of removing or replacing any non-conforming materials, equipment or other items that were incorporated into the Work. The District shall have no obligation to issue the final payment to the Contractor pursuant to the Contract ("Final Payment") unless and until the Contractor satisfies the requirements of this Section.

**Section 5.31 Use of Completed Portions.** The District shall have the right at any time to take possession of and use any completed or partially completed portions of the Work, regardless of whether the entire Work is complete. In no event shall such possession and use by the District be construed as, or deemed to be, acceptance by the District of portions of the Work that is not complete or that has not been completed in accordance with the Contract Documents. In the event such possession and use

delays or increases the cost to the Contractor of completing the remaining Work, the Contractor may submit a claim to the District Representative for additional compensation and/or extension of time.

**Section 5.32 Contractor Warranty.**

**Subsection 5.32.1 General.** In addition to any manufacturer or other warranties and/or guarantees required by the Contract Documents, the Contractor hereby warrants that all Work performed pursuant to the Contract shall be of good quality and conform to all requirements of the Contract Documents, and that the Work shall be free from defective, faulty and/or non-conforming workmanship, materials, equipment, and other items. The Contractor shall repair, replace or correct any and all such defective, faulty, or non-conforming Work as appears or is discovered during the one year period after the date of final acceptance of the Project by the District (or the period of time specified elsewhere in the Contract Documents or in any guarantee or warranty provided by any manufacturer or supplier of equipment or materials incorporated into the Work, whichever is later). The provisions of this Section shall not be construed to limit the warranty on items for which the Contract Documents specify a longer warranty or on items for which the manufacturer provides a longer warranty period, and the Contractor shall be responsible for any latent defects in the Work for the period applicable to latent acts or omissions specified in Section 7030 of the Business and Professions Code.

**Subsection 5.32.2 Performance of Warranty Work.** Within seven days after written notice from the District of any such defect, fault and/or non-conformance, the Contractor shall, at its sole cost and expense, commence and perform with due diligence all Work necessary to repair, replace or correct such defect, fault and/or non-conformance so that the requirements of the Contract Documents are met. Notwithstanding the foregoing, the Contractor shall immediately upon notice from the District undertake any necessary repair, replacement or correction in the event of an emergency or a dangerous condition, when necessary to prevent an interruption in the District's operations, or when necessary to prevent injuries to persons and/or damage to property.

**Subsection 5.32.3 Collateral Damage.** In complying with its warranty obligation, the Contractor shall, at its sole cost and expense, repair, replace or correct any portions of the Project (including work of other contractors and subcontractor(s)) damaged by any defect, fault or non-conformance in the Work, or that become damaged in the course of repair, replacement or correction of defective, faulty, or non-conforming Work.

**Subsection 5.32.4 Extension of Warranty Period.** With respect to any of the Work that is repaired, replaced or corrected during the applicable term of this warranty, the warranty and the Contractor's obligation hereunder shall be extended for an additional one-year period, commencing with the date of acceptance of the repaired, replaced, or corrected Work.

**Subsection 5.32.5 Confirmation of Warranty Work.** The Contractor shall, at its sole cost and expense, perform such tests as the District may require to confirm that any repair, replacement or correction pursuant to this Section complies with the requirements of the Contract Documents.

**Subsection 5.32.6 Warranties for Benefit of District.** Any and all warranties and guarantees of subcontractors, suppliers and manufacturers with respect to any portion of the Work, whether express or implied, are deemed to be obtained by the Contractor for the benefit of the District, regardless of whether or not such warranties and guaranties have been transferred or assigned to the District by separate agreement, and the Contractor agrees to enforce such warranties and guaranties, if necessary, on behalf of the District.

**Subsection 5.32.7 Contractor Failure to Perform.** In the event the Contractor fails to perform, or fails to timely perform, any necessary repair, replacement or correction to the reasonable satisfaction of the District, the District shall have the right, at the Contractor's sole cost and expense, to repair, replace or correct any defective, faulty or non-conforming Work together with any portion of the Project damaged thereby or by the repair, replacement, or correction thereof. The Contractor or, if applicable, its surety, shall reimburse the District for all costs and expenses that the District incurs in connection with any such repair, replacement or correction by the District, or in connection with enforcing the provisions of this Section.

## **PART 6. CHANGES IN THE WORK.**

**Section 6.1 District Instructions.** In giving instructions related to performance of the Work, the Contractor shall comply with instructions of the District Representative related to minor changes in the Work not involving extra cost and not inconsistent with the purpose of the Work, and there shall be no additional compensation to the Contractor on account of such minor changes.

**Section 6.2 District Authority.** For purposes of the Contract, any significant alteration, deviation, or change in the scope, method of performance, nature of materials or price of the Work or the Project, or any other matter materially affecting the performance or nature of the Work or the Project shall be referred to as a "Change in the Work." The District shall have the right to require a Change in the Work, without thereby invalidating the Contract.

**Section 6.3 Change Orders.** Any request for a Change in the Work that involves an adjustment of the Contract Amount or a modification of the time for performance of the Work or portion thereof shall be set forth in a written order for the Change in the Work (each a "Change Order"). Each Party shall propose Change Orders for Changes in the Work that it requests. Any and all modifications of the time for performance of the Work attributable to a Change in the Work must be set forth in the associated Change Order and not left for later determination. No Change Order shall become effective, and the District shall have no liability related thereto for payment or otherwise, unless and until approved and signed by the District and the Contractor and approved by the District Board. Except as expressly provided in the Change Order, all work pursuant to a Change Order shall be performed in accordance with the terms and conditions of the Contract. Notwithstanding the foregoing, in the event of an emergency endangering life or property, the Contractor may rely on the District's oral requests for additional work, which if affecting the Contract Amount and/or time for performance of the Work will be adjusted accordingly by the District. The District will provide oral requests for additional work only to the extent the District Board has expressly delegated such authority.

**Section 6.4 Valuation of Change Orders.** The Parties shall determine and set forth in an applicable Change Order the fair and reasonable value of each Change in the Work, which will be added to or deducted from the amount of the Contract Amount. The Contractor shall, upon request of the District, provide all information required by the District to substantiate the value of a Change in the Work. No time extension shall be granted in conjunction with any Change Order unless the approved Change Order expressly sets forth such adjustment. The valuation of a Change Order shall be determined in one or more of the following ways: (i) by estimate and agreement on a fixed lump-sum amount; (ii) by unit prices specified in the Contract or as agreed to by the Parties; or (iii) by a percentage of Contractor's cost and a fixed fee, in which case the Contractor shall keep detailed records of the net cost of labor and materials. The valuation of each Change Order may as agreed by the Parties include a reasonable amount for overhead and profit, but in no event shall such overhead and profit exceed an

amount equal to ten percent of the total valuation. The District Representative shall certify the amount of each Change Order that does not provide for a fixed lump-sum amount. In the event the Parties are unable to agree on a Change Order valuation method or amount, the Contractor nonetheless shall proceed with any Change in the Work required by the District. In such event, the Contractor shall keep detailed records of the net cost of labor and materials, including, without limitation, any and all vouchers issued in connection with such Change in the Work. Pending final determination of value, payment on account of a Change in the Work shall be made based upon the District Representative's estimate of the value of the Change in the Work, including, if applicable, a reasonable allowance for overhead and profit due to the Contractor.

**Section 6.5 Change Orders Specify Full and Final Compensation.** Except as expressly set forth in any particular Change Order, each Change Order shall be deemed and construed to include all change(s) required pursuant to the Change Order, including, without limitation, any and all extensions of time and overhead, acceleration costs, profit, general conditions costs, expenses, and other direct and indirect costs and expenses of such work and/or changes. In addition, each Change Order shall be deemed and construed to include all necessary adjustments attributable to cumulative impacts of that and any and all preceding Change Orders, whether such impacts relate to scheduling, productivity, or other matters. By signing a Change Order, the Contractor shall be deemed and construed to have waived any and all claims and rights to any adjustments to the Contract Amount and/or time for performance of the Work other than as are set forth in the Change Order, and the Contractor may not thereafter attempt to hold the District responsible for any interference, delay, acceleration, or other effect on the Work and/or additional costs attributable to the change(s) required pursuant to the Change Order. To the extent provided in Section 8.15 of these General Provisions, the Contractor shall defend, indemnify, and hold the District harmless from any and all claims by any subcontractor, vendor, or consultant of the Contractor that are alleged to arise in whole or in part from any Change Order(s), including without limitation, any and all claims for extensions of time and overhead, delays, delay damages, acceleration costs, profit, general conditions costs, expenses, and other direct and indirect costs.

## **PART 7. CONTRACTOR COMPENSATION.**

**Section 7.1 Application for Payment.** The Contractor shall submit to the District Representative, on or before the fifth day of each month, an itemized application for payment for the portion of the Work completed during the prior month ("Progress Payment Application"). The Progress Payment Application shall be in a format approved by the District. The Contractor may call upon the Inspector for assistance in preparing any Progress Payment Application and, prior to submittal to the District Representative, shall permit the Inspector to review the Progress Payment Application. The Contractor shall certify in the Progress Payment Application that the portion of the Work for which payment is requested has been satisfactorily completed and/or that any materials specified in the Progress Payment Application not already incorporated into the Project are stored where indicated. Each Progress Payment Application must identify: (i) the portion and amount of Work completed since the last Progress Payment Application; and (ii) the portion of the requested payment amount attributable to each subcontractor, material supplier, and other entity that is entitled to a portion of the payment amount. Each Progress Payment Application shall be accompanied by an updated construction schedule illustrating the actual Work completed to date in relation to the approved construction schedule. If there is a discrepancy between the actual Work completed and the Work required pursuant to the construction schedule (i.e., the Work is either ahead of schedule or behind schedule), the Contractor shall include a detailed explanation of such discrepancy with the Progress Payment Application. Payment to the Contractor shall not be deemed to be acceptance, acquiescence, or waiver

by the District of any of its rights with respect to any such discrepancy or any deficiency in the Work. The Contractor shall support each Progress Payment Application with such information as reasonably will be necessary for the District Representative to verify the requested payment amount. Payment to the Contractor may be delayed if the Contractor fails to submit complete and accurate information in support of its Progress Payment Applications.

**Section 7.2 Verification of Payment Application.** The District Representative and/or Architect shall review each Progress Payment Application and, as soon as practicable, but not later than seven days after receipt of a Progress Payment Application, shall: (i) certify that the Progress Payment Application is correct in all aspects and should be paid by the District; (ii) recommend to the District that it reject the Progress Payment Application, stating the reason(s) why rejection is appropriate; or (iii) require that the Contractor provide additional information that the District Representative reasonably determines is necessary to verify any requested payment amount. In the event the District rejects the Progress Payment Application, the Contractor may resubmit the Progress Payment Application with additional or new information establishing why payment should be made despite the reason(s) set forth in the District's initial rejection.

**Section 7.3 Progress Payments.** The District shall pay the undisputed amount of any Progress Payment Application, less any amounts that may be withheld or retained pursuant to the Contract or law, within thirty days of receipt thereof and in accordance with Public Contract Code Section 20104.50. If the District has requested additional information in support of a Progress Payment Application, the time for payment pursuant to that Progress Payment Application shall be extended by the number of days required for the Contractor to provide the requested information but reduced by the number of days the District exceeds the seven-day return requirement described in Section 7.2 of these General Provisions. The District shall pay interest, at the rate set forth in Code of Civil Procedure Section 685.010(a), on any amount not paid within the time required by Public Contract Code Section 20104.50 and the Contract, provided that such amount is not subject to dispute or a request for additional information.

**Section 7.4 Retention.** Unless provided otherwise in the Special Provisions, the District shall retain five percent of the amount to be paid to the Contractor pursuant to each approved Progress Payment Application ("Retention"), and the total amount of Retention shall not exceed five percent of the Contract Amount. However, if the Special Provisions provide for Retention in excess of five percent, the District shall withhold such greater percentage of each approved Progress Payment as Retention, and, in such event, the total amount of Retention shall not exceed an amount equal to that percentage of the total Contract Amount. The District shall release the Retention to the Contractor with the Final Payment made pursuant to Section 7.9 of these General Provisions. In the event of any dispute between the District and the Contractor, the District, as provided by Public Contract Code Section 7107, may withhold from the Final Payment an amount not exceeding one hundred and fifty percent of the amount in dispute.

**Section 7.5 Ownership of Work.** As security for partial, progress or other payments, title to the portion of the Work for which such payments are made shall pass to the District at the time of payment. The Contractor shall retain title to all new materials and equipment until incorporated into the Work. However, all Work shall be at the Contractor's risk exclusively until final completion and acceptance of the Project by the District. To the extent that title has not previously been vested in the District by reason of any such payments, full title shall pass to the District upon delivery of the completed Work as specified in the Contract. Such transferred title shall in each case be good, free and clear from any and all security interests, liens, and other encumbrances. The Contractor promises and agrees that it shall not pledge, hypothecate or otherwise encumber the Work, materials or other items

hereby subject to transfer of title in any manner that would result in any lien, security interest, charge, or claim upon or against said items. Any such transfer of title shall not imply acceptance by the District, shall not relieve the Contractor from the responsibility to strictly comply with the Contract, and shall not relieve Contractor of responsibility for, any loss of or damage to the Work, materials, or other items on the Project.

**Section 7.6      *Securities In Lieu of Retention.*** Upon request to the District, the Contractor shall be permitted, in accordance with Public Contract Code Section 22300, to substitute securities in lieu of the Retention withheld by the District in order to ensure Contractor's performance under the Contract. Alternatively, the Contractor may request that the District pay any Retention earned by Contractor directly to an escrow agent who shall, as directed by the Contractor, invest the Retention in securities. Any escrow agreement shall be substantially in the form set forth in, and any securities invested or substituted in lieu of Retention shall be of the type permitted pursuant to, Public Contract Code Section 22300. The Contractor shall be responsible for all costs (including, without limitation, the District's costs) attributable to any investment or substitution of securities in lieu of Retention and/or any costs incurred in connection with establishing and maintaining an escrow account.

**Section 7.7      *Deductions for Uncorrected Work.*** The District may determine, in its sole discretion, not to correct all or any portion of the Work or Project that is damaged or that was not completed in accordance with the Contract and, in such event, if applicable, an equitable deduction from the Contract Amount shall be made on account of such damaged or incomplete work.

**Section 7.8      *Other Withholdings.*** In addition to the Retention, the District may withhold from the Final Payment or from amounts payable pursuant to any approved Progress Payment Application all amounts necessary to protect District from any loss or liability that has or might result from: (i) Liquidated Damages; (ii) the costs to the District of performing any obligation of the Contractor related to the Work that the Contractor has failed to timely perform or has performed inadequately; (iii) failure of the Contractor to timely correct defective Work; (iv) any stop payment notice(s) related to the Work; (v) reasonable doubt that the Work can be completed for the unpaid balance of the Contract Amount or prior to any scheduled completion date; (vi) unsatisfactory progress, execution or performance of the Work; (vii) unauthorized deviations from the Contract; (viii) failure of the Contractor to maintain or timely submit proper and sufficient documentation as required by the Contract or by the District during performance of the Work; (ix) erroneous or false estimates by the Contractor of the value of the Work performed; (x) expenses, losses, or damages incurred by the District for which Contractor is liable pursuant to the Contract; (xi) damage caused by the Contractor or its Work to the Project or to the work of any other prime contractor or subcontractor performing work on the Project; and (xii) any other sums that the District is entitled to withhold or recover from the Contractor pursuant to law or the Contract. The failure by the District to withhold any such amount from any payment, or from a particular payment, to the Contractor shall not constitute a waiver of the District's right to such amount.

**Section 7.9      *Final Payment.*** The Inspector shall provide written certification to the District when, as determined by the Inspector, the Contractor has satisfactorily completed the Work and all other obligations pursuant to the Contract Documents. The Inspector shall indicate in the certificate, based on actual measurements, the whole amount and value of the Work accomplished by the Contractor and that all "punch list" items have been satisfactorily completed. The District shall thereafter inspect the Work and determine whether all of the Work has been completed in accordance with the terms of the Contract Documents and should be accepted by the District Board. Not sooner than thirty-five days, and not later than sixty days, after acceptance of the Work by the District Board, the District shall issue the Final Payment and accumulated Retention to the Contractor, subject to withholding of disputed or other amounts as permitted by applicable law and/or the Contract



Documents. The District, within fifteen days after acceptance of the Work by the District Board, may cause a Notice of Completion for the Work to be filed in the office of the Assessor/Recorder/County Clerk for the County of San Diego ("County Recorder").

**Section 7.10 Waiver and Release.** Notwithstanding any other provision of the Contract, as a condition precedent for each payment to the Contractor hereunder: (i) the Contractor must complete, sign and submit to the District a conditional waiver and release in accordance with, and in substantially the form set forth in, Civil Code Section 8132, for the full amount of the payment; (ii) the Contractor must complete, sign and submit to the District an unconditional waiver and release, in substantially the form set forth in Civil Code Section 8134, for all amounts previously paid to the Contractor and for which the Contractor has not already submitted an unconditional waiver; and (iii) a completed and signed unconditional waiver and release, in substantially the form set forth in Civil Code Section 8134, for each subcontractor, materials supplier and other entity that has been paid by the Contractor, but that has not already submitted an unconditional waiver and release for all such payment amounts. Upon completion of all of the Work, and issuance of Final Payment and Retention to Contractor in connection with the Project, the District may require that Contractor complete, sign and submit to the District an unconditional waiver and release upon Final Payment in accordance with, and in substantially the form set forth in, Civil Code Section 8138. In addition, the District may require that the Contractor submit to the District an affidavit to the effect that such releases account for all the labor and material used in connection with the Work for which a stop payment notice could be filed. In the event any subcontractor, materials supplier, or other entity or person refuses to provide a release in full, the Contractor may provide the District with a bond satisfactory to the District to indemnify the District against any stop payment notice that may be filed by such entity or person. If any stop payment notice remains unsatisfied after the District has made the Final Payment to the Contractor, the Contractor shall pay to the District all amounts, if any, that the District may be compelled to pay in discharging such stop payment notice, together with the District's costs and expenses related thereto, including attorneys' fees and costs.

**Section 7.11 Claims for Extra Cost.** If the Contractor claims that instructions related to the Work resulted in costs to the Contractor that were not contemplated and are not included within the Contract Amount, the Contractor shall give written notice thereof to the District Representative within a reasonable time, but not in excess of five days after the receipt of such instructions. In the event of any such claim, except in an emergency in which life or property is endangered, the Contractor shall not commence execution of the portion of the Work that is affected by such claim unless and until directed to do so by the District. In the event the District Representative determines that any such claim is valid, the Contract Amount shall be adjusted as provided for a Change in the Work. The Contractor shall bear the risk, cost, and expense of any Change in the Work undertaken without prior approval of the District.

**Section 7.12 Delay Damages.** The Contractor shall not claim or be entitled to receive any compensation or damages because any portion of the Project at any time has not progressed or is not sufficiently complete for Contractor to timely proceed or continue with any portion of the Work, except if and to the extent such delay is the result of an unreasonable act of the District not within the contemplation of the Parties. Notwithstanding the foregoing, the Contractor shall not claim or be entitled to compensation for any such otherwise compensable delay in the event of a concurrent delay resulting from acts or omissions of the Contractor or its subcontractors or suppliers. IN THE EVENT OF A PERCEIVED DELAY, A CONDITION PRECEDENT FOR ANY CLAIM BY CONTRACTOR SHALL BE COMPLIANCE WITH THE NOTICE REQUIREMENTS SET FORTH IN SECTION 5.6 OF THESE GENERAL PROVISIONS. If the Contractor fails to give timely notice of a delay in accordance with Section 5.6 of these General Provisions, the Contractor shall have no right or entitlement to any compensation or extension of time in connection with such delay.

## **PART 8. INSURANCE AND INDEMNIFICATION.**

**Section 8.1 General Liability Insurance.** Prior to commencing the Work, the Contractor must have in effect, and the Contractor must maintain in effect at all times as required by this Section, a policy of broad-form commercial general liability insurance (“General Liability Policy”), written on an “occurrence” basis, covering claims for bodily injury, including death, property damage, and consequential damages that may arise out of or result from the Contractor’s performance of the Contract or from actions taken in connection with the Work, whether such actions are taken by the Contractor, by any subcontractor of the Contractor, or any person directly or indirectly employed by any of them. Not as a limitation on the foregoing, the General Liability Policy must provide coverage for both the ongoing and completed operations of the Contractor, and for the indemnification obligations assumed by the Contractor pursuant to the Contract Documents. The General Liability Policy must provide coverage with minimum coverage limits as specified in the Special Provisions. If an aggregate limit applies to the General Liability Policy, not less than the minimum aggregate coverage limit specified in the Special Provisions must apply specifically to the Project and the Contract, by means of either an endorsement or a separate “following form” excess policy. The Contractor must keep the General Liability Policy in full force and effect for at least one year after the date of Final Payment to the Contractor to ensure that coverage for products-completed operations remains in effect at least for such one-year period.

**Section 8.2 Vehicle Liability Insurance.** Prior to commencing the Work, the Contractor must have in effect, and the Contractor must maintain in effect at all times prior to final completion and acceptance of the Work, a policy of vehicle liability insurance, written on an occurrence basis, providing coverage for all motor vehicles (whether owned, leased, rented, or borrowed) that are driven or used in connection with the Work (“Vehicle Liability Policy”). The Vehicle Liability Policy must, by separate endorsement, name the District as an additional insured and must include a standard waiver of the insurer’s rights of subrogation against the District. The Vehicle Liability Policy must provide coverage with minimum coverage limits as specified in the Special Provisions. If an aggregate limit applies, not less than the minimum aggregate coverage limit specified in the Special Provisions must apply specifically to the Project and the Contract, by means of endorsement or separate “following form” excess policy.

**Section 8.3 Workers Compensation Insurance.** In accordance with Labor Code Sections 1860 and 1861, and concurrently with execution and delivery of the Contract, the Contractor shall execute and deliver to the District the “Certification Regarding Workers Compensation” form included in the Required Contract Forms to thereby acknowledge its responsibility to secure workers’ compensation insurance in compliance with Labor Code Section 3700 *et seq.* Prior to commencing the Work, the Contractor must have in effect, and the Contractor must maintain in effect at all times prior to full and final completion of the Work, a policy of workers’ compensation insurance in compliance with Section 3700 of the Labor Code and other applicable provisions of law (“Workers Compensation Policy”). Within seven days following receipt of the Notice of Award, the Contractor must provide to the District such Certificates of Insurance as evidence that the Contractor has such insurance coverage in effect.

### **Section 8.4 Builder's All-Risk Insurance.**

**Subsection 8.4.1 General Requirement.** If so specified in the Special Provisions, the Contractor must procure a policy of builder’s all-risk insurance, written on a non-reporting, completed value basis, providing coverage in an amount not less than the greater of: (i) the full estimated replacement cost of the Project assuming the Work has been completed; or (ii) the Contract Amount (“Builder’s All-Risk Policy”). The Builder’s All-Risk Policy must apply, at a minimum, to: (i) completed

Work and the Project as improved by the Work; (ii) Work in progress; (iii) temporary structures and improvements; (iv) materials, supplies, and equipment stored on the Project Site; (v) materials, supplies, and equipment stored at off-site locations or in transit; and (vi) operational and performance testing, commissioning, and start-up.

**Subsection 8.4.2 All-Risk Coverage.** The Builder's All-Risk Policy must cover: (i) losses arising from causes that include, without limitation, fires, windstorms, lightening, explosions, theft, earth movement, collapse, and water damage; (ii) costs associated with clean-up, demolition, repair or other correction of covered losses, including, without limitation, fees for necessary architectural, engineering and other professional services; and (iii) all ensuing or consequential losses attributable to causes of loss excluded under the Builder's All-Risk Policy, including, without limitation, faulty design or workmanship. The Builder's All-Risk Policy must be endorsed for extended coverage, vandalism, malicious mischief, and theft, including theft of materials not then incorporated into the Work. Any exclusion of losses attributable to faulty design or workmanship shall not exceed the total costs the District would have incurred to repair or otherwise correct the fault if it had been discovered prior to the loss having occurred.

**Subsection 8.4.3 Earthquake and Flood Coverage.** The foregoing provisions of this Section 8.4 shall not be deemed or construed to require that the Builder's All-Risk Policy include coverage for earthquakes and/or flooding attributable to natural causes. However, the District may require that the Contractor obtain an endorsement to the Builder's All-Risk Policy to provide earthquake and/or flood insurance for the Project, in which event the District shall be responsible for the cost of the endorsement.

**Subsection 8.4.4 Loss Payees and Additional Insureds.** The Builder's All-Risk Policy must name or be endorsed to name the District and the Contractor as loss payees (or, if applicable, additional insureds), including, without limitation, for the purposes of any tax-exempt bond proceeds used to fund the Project, and the District shall for such purposes be deemed the owner of all work and materials on the Project Site or stored for use on the Project Site. The payment by the District of any Progress Payment, in and of itself, shall not be deemed or construed to: (i) create an insurable interest for the District; or (ii) relieve the Contractor of responsibility it otherwise may have for losses arising from any direct physical loss, damage, or destruction incurred prior to final completion and acceptance of the Work.

**Section 8.5 Contractor Insurance is Primary.** The coverages provided by each of the General Liability Policy, the Vehicle Liability Policy, and, if applicable, the Builder's All-Risk Policy shall be primary and not contributing with respect to any insurance or self-insurance programs covering the District and/or any of the District Agents (defined in Section 8.15 of these General Provisions).

**Section 8.6 Insurer Standards.** Each of the General Liability Policy, the Vehicle Liability Policy and, if applicable, the Builder's All-Risk Policy must be issued by an insurer that is licensed to do business in this State and that has, as determined by the A.M. Best Company, a "Financial Strength Rating" of not less than "B+" (B plus), a "Ratings Outlook," if assigned, of either stable or positive, and a "Financial Size Category" of not less than "VIII." If a "Ratings Outlook" has been assigned to any such insurer that is not either stable or positive, the District may consider the insurer's Rating's Outlook and all other relevant factors in determining whether the insurer is satisfactory, and, if the District reasonably determines that there may be a significant risk in accepting any insurance policy issued or to be issued by such insurer, then, upon request of the District, the Contractor must obtain such insurance policy through another insurer that satisfies the standards set forth in this Section.

**Section 8.7 Additional Insureds.** The General Liability Policy and the Vehicle Liability Policy each must name or be endorsed to name the District as an additional insured. Each endorsement specifying any additional insured must be ISO Form CG 20 10 11 85 or an equivalent endorsement reasonably acceptable to the District. Each additional insured endorsement shall include a “primary insurance clause” stating to the effect that: “The insurance afforded by this policy for the benefit of the additional insureds shall be primary insurance, and any insurance maintained by the additional insureds shall be excess and non-contributory with the insurance provided hereunder.” The coverage provided to the additional insureds must be at least as broad as the coverage provided to the Contractor and may not contain any additional exclusionary language or limitations applicable only to the additional insureds.

**Section 8.8 Cross-Liability and Waivers of Subrogation.** Each of the General Liability Policy, the Vehicle Liability Policy, and, if applicable, the Builder’s All-Risk Policy must be endorsed with a cross-liability endorsement (separation of insureds) and include a waiver of the insurer’s rights of subrogation against each person or entity that is an additional insured or loss payee. The Workers Compensation Policy must be endorsed to include a waiver of the insurer’s rights of subrogation against the District. A waiver of subrogation shall be effective with respect to each applicable person or entity regardless of whether the person or entity: (i) has a right to indemnification; (ii) has an obligation to indemnify any other person or entity; (iii) paid any premium for the applicable insurance; or (iv) has an insurable interest in any property. The Contractor shall indemnify, defend and hold-harmless the District, in accordance with Section 8.15 of these General Provisions, with respect to any and all subrogation claims arising from any of the General Liability Policy, the Vehicle Liability Policy, the Builder’s All-Risk Policy (if applicable), or the Workers Compensation Policy.

**Section 8.9 Premiums, Deductibles and Self-Insured Retentions.** Except as provided in Subsection 8.4.3 of these General Provisions, the Contractor shall be solely responsible and liable for paying any and all premiums and other costs incurred in obtaining and maintaining the General Liability Policy, the Vehicle Liability Policy, the Builder’s All-Risk Policy (if applicable), and the Workers Compensation Policy, including, without limitation, any and all renewal premiums. Subject to written approval by the District, which the District may grant or withhold in its reasonable discretion, one or more of such insurance policies may be subject to a deductible or self-insured retention. Upon reasonable request of the District, the Contractor shall either: (i) cause any such deductible or self-insured retention to be reduced or eliminated; or (ii) obtain and provide to the District a bond or bonds guaranteeing payment of the deductible or self-insured retention, together with any losses and related investigations, claims, administrative and legal costs and expenses. Each Certificate of Insurance (defined in Section 8.10 of these General Provisions) that evidences any such insurance policy must specify any and all deductibles applicable to the policy. The Contractor shall be solely responsible and liable for any and all such deductibles and self-insured retentions. However, each insurance policy subject to any deductible or self-insured retention shall provide, or be endorsed to provide, for payment or satisfaction of the deductible or self-insured retention by the District in the event of Contractor’s insolvency or inability to otherwise pay or satisfy the deductible or self-insured retention. Contractor’s indemnification and other obligations pursuant to Section 8.15 of these General Provisions shall apply with respect to any and all claims arising from such premiums, deductibles and/or self-insured retentions.

**Section 8.10 Evidence of Coverage.** Within seven days following receipt of the Notice of Award, the Contractor must provide to the District, for each of the General Liability Policy, the Vehicle Liability Policy, the Builder’s All-Risk Policy (if applicable), and the Workers Compensation Policy, a certificate of insurance evidencing that such insurance is in effect (each a “Certificate of Insurance”), together with any and all endorsements to such policies required pursuant to this Part 8 of these

General Provisions. Each Certificate of Insurance must: (i) be executed by a duly authorized officer, agent, or other representative of the insurer; (ii) include an original handwritten signature of the insurer's representative, not a stamped or printed signature; and (iii) must certify the names of the insured, any additional insureds, the type and amount of the insurance, the location and operations to which the insurance applies, and the expiration date of such insurance. The Contractor must provide to the District an updated Certificate of Insurance for each renewal of any such insurance policy not less than thirty days prior to any expiration of the policy. Each renewal and replacement of any such policy that, as permitted by this Part 8 of these General Provisions, is written on a "claims made" basis must have a retroactive date that is prior to the date the Contractor was initially required to have such insurance policy in effect pursuant to this Part 8. If any Certificate of Insurance associated with any of the General Liability Policy, the Vehicle Liability Policy, the Builder's All-Risk Policy (if applicable), or the Workers Compensation Policy sets forth language to the effect that it "does not amend, extend or alter the coverage" of the insurance policy, or that the coverage available pursuant to the policy "is subject to all of the terms, exclusions, and conditions of the policy," then, notwithstanding Section 8.12 of these General Provisions, the Contractor, prior to commencing the Work, must provide to the District a certified copy of such insurance policy and all associated endorsements, riders, *et cetera*.

**Section 8.11 Mandatory Notice from Insurer of Change in Coverage.** Each of the General Liability Policy, the Vehicle Liability Policy, the Builder's All-Risk Policy (if applicable), and Workers Compensation Policy, and each associated Certificate of Insurance, must require or be endorsed to require that the insurer notify the District not less than thirty days prior to any cancellation, termination, reduction in coverage, or expiration without renewal of such policy, or, in the case of any cancellation for non-payment of premium, not less than ten days prior to cancellation. Language in any such insurance policy or Certificate of Insurance to the effect that the insurer shall "endeavor" to provide such notice, or to the effect "that failure to mail such notice shall impose no obligation and liability upon the company, its agents or representatives," shall not be acceptable.

**Section 8.12 District Review and Approval of Insurance Policies.** Within ten days of a request from the District, the Contractor must provide to the District a certified copy of any of the General Liability Policy, the Vehicle Liability Policy, the Builder's All-Risk Policy (if applicable) and/or the Workers Compensation Policy as requested by the District, together with any and all associated Certificates of Insurance, endorsements, riders, *et cetera*. Each of such insurance policies and associated other documents shall be subject to review and approval by the District in regard to compliance with the requirements of this Part 8 of these General Provisions. No such review by the District, and no failure by the District to undertake any such review, shall be deemed or construed to be an assumption of liability by the District or to constitute a waiver of any non-compliance by the Contractor with the requirements of this Part 8 of these General Provisions.

**Section 8.13 Subcontractor Insurance.** The Contractor must require in its subcontracts applicable to the Work that each subcontractor obtain and maintain insurance coverage in compliance with all of the preceding requirements of this Part 8 of these General Provisions, except that: (i) no subcontractor need carry a Builder's All-Risk Policy; and (ii) coverage limits for subcontractor General Liability Policy and Vehicle Liability Policy shall be as specified in the Special Provisions. The Contractor shall be responsible for ensuring that any and all subcontractors have such insurance in effect and for providing all documentation of the subcontractors' insurance coverage (i.e., copies of insurance policies and Certificates of Insurance) to the District within the time(s) required by this Part 8 of these General Provisions. The Contractor shall indemnify, defend and hold-harmless the District, in accordance with Section 8.15 of these General Provisions, with respect to any and all claims, demands, actions, costs, expenses, and other liabilities arising from the failure of any subcontractor to have in effect the insurance required pursuant to this Part 8 of these General Provisions.

**Section 8.14 Waiver of Claims.** Each of the District and the Contractor hereby waives any and all rights it may have against the other pursuant to the Contract to the extent the waiving Party is compensated for claims, damages, or other liabilities by any of the insurance required pursuant to this Part 8 of these General Provisions. The Contractor shall require that in its subcontracts applicable to the Work that each subcontractor waive any and all rights it may have against the District in connection with the Work to the extent the subcontractor is compensated for claims, damages, or other liabilities by any of the insurance required pursuant to this Part 8 of these General Provisions. The Contractor shall indemnify, defend and hold-harmless the District, in accordance with Section 8.15 of these General Provisions, with respect to any and all claims, demands, actions, costs, expenses, and other liabilities arising from the failure of any subcontractor to provide the waiver as required pursuant to this Section.

**Section 8.15 Indemnification.** The Contractor shall indemnify, defend and hold-harmless the District, the District Board and each individual member thereof, and the District's other officers, employees and agents (collectively, not including the District, the "District Agents"), and each of them, against and from any and all claims, demands, actions, damages, losses, costs, expenses (including, without limitation, reasonable attorneys' fees and expenses), and other liabilities of whatever nature that arise from or in connection with the performance of the Contract or of the Work by Contractor or its officers, agents, employees, or subcontractors. The Contractor shall reimburse the District for all damages, expenses and losses incurred by the District as a consequence of any claim, demand, action or other proceeding that is within the scope of the foregoing provision of this Section, including, without limitation, any and all disputes between Contractor and any of its subcontractors. However, the Contractor shall not be liable or responsible pursuant to this Section to the extent any claim, demand, action, damage, loss, cost, expense or other liability is attributable to the active negligence, sole negligence or willful misconduct of the District or any of the District Agents, in which event the District and the Contractor shall be liable on a comparative basis. The requirements of this Section shall be in addition to any other indemnification provisions contained in the Contract Documents and shall survive termination of the Contract. Any and all obligations set forth in the Contract Documents requiring that the Contractor indemnify, defend and hold-harmless the District (including, without limitation, this Section) shall be deemed and construed as an obligation to indemnify, defend and hold-harmless the District, the District Agents, and each of them.

**Section 8.16 Subcontractor Indemnification.** The Contractor shall require that in its subcontracts applicable to the Work that each subcontractor indemnify, defend and hold-harmless the District in connection with the Work to the extent provided in Section 8.15 of these General Provisions. The Contractor shall indemnify, defend and hold-harmless the District, in accordance with Section 8.15 of these General Provisions, with respect to any failure of any subcontractor to indemnify, defend, and hold-harmless the District as required pursuant to this Section.

## **PART 9. BOND REQUIREMENTS.**

**Section 9.1 Payment Bond.** Concurrent with execution and delivery of the Contract, the Contractor must deliver to the District a "Payment Bond" in the form included in the Required Contract Forms, which shall have been duly executed by the Contractor and a Qualified Surety (defined in Section 9.3 of these General Provisions). The payment bond must have a penal sum equal to one hundred percent of the Contract Amount, and shall be exclusive of any obligation under the performance bond required pursuant to Section 9.2 of these General Provisions. The District shall not be required to issue any payment whatsoever to the Contractor pursuant to the Contract unless and until the District has received and approved such payment bond.

**Section 9.2 Performance Bond.** Concurrent with execution and delivery of the Contract, the Contractor shall deliver to the District a "Performance Bond" in the form included in the Required Contract Forms, which shall have been duly executed by the Contractor and a Qualified Surety. The performance bond must have a penal sum equal to one hundred percent of the Contract Amount, and shall be exclusive of any obligation under the payment bond required pursuant to Section 9.1 of these General Provisions. The District shall not be required to issue any payment whatsoever to the Contractor pursuant to the Contract unless and until the District has received and approved such performance bond.

**Section 9.3 Surety Qualifications.** The payment and performance bonds required pursuant to Sections 9.1 and 9.2, respectively, of these General Provisions each must have been executed and issued by a surety that satisfies the requirements of this Section. The surety must be an "admitted surety insurer" as defined in California Code of Civil Procedure Section 995.120. In order to ensure that the surety is an "admitted surety insurer," the bidder or Contractor must attach to such bonds either of the following documents as required by California Code of Civil Procedure Section 995.311: (i) a copy of information printed from the website of the California Department of Insurance confirming that the surety is an admitted surety insurer; or (ii) a certificate from the County Recorder confirming that the surety is an admitted surety insurer. The surety that issues the performance bond must have a current A.M. Best Company "financial strength rating" of not less than "A-" (A minus) and a "financial size category" of not less than "VIII." A surety that meets the requirements of this Section shall be deemed to be a "Qualified Surety" for purposes of the Contract. If either or both of the payment bond or performance bond submitted by the Contractor was not executed and issued by a Qualified Surety, the Contractor, within forty-eight hours of notice from the District Representative and prior to commencing the Work, must submit a replacement bond or bonds that satisfy the requirements of this Section, and if the Contractor fails to submit such replacement bond(s), the Contractor shall be deemed in material breach of the Contract. The foregoing requirement to provide a replacement payment or performance bond shall also be applicable in the event the surety, during the course of construction of the Project, loses its status as an "admitted surety insurer" as defined in Code of Civil Procedure Section 995.120.

**Section 9.4 Increase in Bond Penal Sum.** In the event the Contract Amount is increased in accordance with the Contract, the Contractor, upon request of the District, shall promptly cause the amount of the payment and performance bonds to be correspondingly increased and shall promptly deliver satisfactory evidence thereof to the District. If the Contractor fails to provide to the District any bond required pursuant to the Contract, the District, in its sole discretion, may terminate the Contract for cause.

**Section 9.5 Sufficiency of Bonds.** If, in the reasonable opinion of the District, either or both of the payment bond or performance bond required pursuant to this Part 9 of these General Provisions, or the surety issuing either or both of such bonds, is or becomes insufficient or unsatisfactory, the Contractor shall renew or replace such bond within forty-eight hours of notice from the District Representative, and any failure by the Contractor to do so shall be deemed a material breach of the Contract.

## **PART 10. SUSPENSION OR TERMINATION.**

**Section 10.1 Suspension of Work by District.** The District, in its sole discretion, may at any time suspend performance of the Work and/or the Project by giving written notice to Contractor, and the suspension shall be effective upon receipt of such notice by the Contractor. Upon receipt of such

notice, the Contractor shall immediately commence the process of suspending the Work, making safe any work in progress but otherwise taking steps to cease further progress on the Project. The District, consistent with the provisions of the Contract, shall pay the Contractor for all Work adequately performed up to the effective date of such suspension and for work reasonably required to eliminate safety hazards. Contractor shall resume its Work on the Project within twenty calendar days following written notice from the District to further proceed with Work on the Project.

**Section 10.2 Termination for Convenience.** The District, in its sole discretion, and without need for cause, may at any time terminate the Contract, or any portion thereof, by giving written notice to the Contractor, and such termination shall be effective upon receipt of such notice by the Contractor. Upon receipt of such notice, the Contractor shall immediately commence the process of terminating the Work, making safe any work in progress but otherwise taking reasonable steps to cease further progress on the Project. The District, consistent with the provisions of the Contract, shall pay Contractor for all Work adequately performed up to the effective date of the termination for convenience as for work reasonably required to eliminate safety hazards. In the event of a termination for convenience, the Contractor shall not be entitled to any profits, overhead or general conditions costs for any portion of the Work that was not performed prior to termination or to compensation for costs related to discontinuing the Work. Notwithstanding a termination pursuant to this Section, the Contractor and its surety shall continue to be responsible and liable in accordance with the Contract Documents and applicable law for any and all defects in quality, damage to property, injury to any person, and other matters arising from the Work performed prior to the termination.

**Section 10.3 Termination for Cause.**

**Subsection 10.3.1 Events of Default.** Each of the following events shall be deemed a default by the Contractor of its obligations pursuant to the Contract (each an “Event of Default”):

- (i) Contractor is adjudged bankrupt, makes a general assignment for the benefit of creditors, or a receiver is appointed on account of Contractor’s insolvency;
- (ii) as reasonably determined by the District, the Contractor refuses or fails to provide a sufficient number of properly skilled workmen or the proper materials or supplies as are necessary for timely and/or proper completion of the Work;
- (iii) Contractor fails to promptly pay subcontractors for material or labor;
- (iv) Contractor fails to comply with any laws, ordinances, or instructions of the District applicable to the District; and
- (v) Contractor or any of its subcontractors otherwise fail to comply with any material provision of the Contract.

**Subsection 10.3.2 Opportunity to Cure.** If an Event of Default occurs, the District may serve notice on the Contractor and its surety(ies) describing the unsatisfactory condition or violation that constitutes a default by the Contractor (“Notice of Default”). The Contractor shall have forty-eight hours after service of any such Notice of Default to cure the Event of Default specified in the Notice of Default or to make arrangements satisfactory to the District for cure of the Event of Default. Notwithstanding the foregoing, in the case of an Event of Default pursuant to clause (i) of Subsection 10.3.1 of these General Provisions, the Contractor shall have thirty days to cure or make arrangements satisfactory to the District for cure of the Event of Default.



**Subsection 10.3.3 District Remedies for Failure to Cure.** Upon failure of the Contractor to cure or make satisfactory arrangements for cure of an Event of Default in accordance with Subsection 10.3.2 of these General Provisions, the District may, at its option: (i) take such action as, in the District's opinion, is necessary to correct or cure the Event of Default and deduct the cost thereof from any amounts due or to become due to Contractor pursuant to the Contract; (ii) proceed to terminate the Contractor's right to perform the Work; or (iii) take such other action as is permitted by the Contract or applicable law. In the event the District elects to terminate the Contractor's right to perform the Work, the District shall schedule and conduct a hearing on the matter, and the Contractor shall be permitted to attend and present evidence at such hearing to support a determination by the District that it should NOT terminate the Contractor's right to perform the Work. The hearing shall be conducted by the District's Assistant Superintendent of Business Services or designee, who shall make a recommendation to the District Board. Unless specified otherwise therein, a decision by the District Board shall be effective immediately. Notwithstanding a termination pursuant to this Section, the Contractor and its surety shall continue to be responsible and liable, in accordance with the Contract Documents and applicable law for any and all defects in quality, damage to property, injury to any person, and other matters arising from the Work performed prior to the termination.

**Subsection 10.3.4 Effect of Termination for Cause.** In the event of any termination for cause pursuant to this Section 10.3, the District shall be entitled to withhold and retain from any payment due to the Contractor all amounts necessary to offset any costs, expenses (including, but not limited to, attorneys' fees), losses and/or damages incurred by the District as a result of the termination for cause. If the remaining amounts potentially payable to the Contractor pursuant to the Contract are insufficient to offset such costs, expenses, losses and/or damages, the Contractor and/or its performance bond surety shall reimburse the District for the uncompensated balance of such costs, expenses, losses and/or damages, including, without limitation, any uncompensated costs to complete the Work. The District's rights pursuant to the Contract are in addition to, and not in lieu of, any other rights or remedies available to the District in the event of a termination for cause. In addition, the following provisions shall also apply in the event of any termination for cause pursuant to this Section 10.3:

- (i) The Contractor shall not be entitled to further compensation until satisfactory completion and acceptance by the District of all of the Work.
- (ii) The District shall give written notice of a termination pursuant to this Section 10.3 to both the Contractor and the Contractor's performance-bond surety. The surety shall thereafter have the right to take over and perform the Contract, provided, however, that, if the surety does not, within seven calendar days after service of the notice of termination, notify the District that the surety intends to take over and perform the Contract, or if the surety does not commence performance of the Contract within twenty days after providing such notice to the District, the District may take over and complete the Work by any means the District may deem appropriate, for the account of and at the expense of the Contractor, and the Contractor and its surety shall be liable to the District for costs thereby incurred by the District in excess of any remaining portion of the Contract Amount that otherwise would be payable to the Contractor.
- (iii) In the event the District takes over the Work, the District may, without liability for doing so: (1) take possession of the Work and the Project Site; (2) take possession of all materials, tools, equipment and appliances located at the Project Site and use them in connection with completion of the Project; (3) procure, upon such terms and in such manner as it may determine appropriate, services required to complete the Work; (4) require that the Contractor provide to

the District any and all finished or unfinished documents, data, diagrams, drawings, materials or other matter prepared or built by Contractor in connection with its performance of the Contract; and (5) complete the affected portion(s) of the Project by whatever means and methods the District may deem to be in its best interests, including, but not limited to, calling upon Contractor's surety to complete the Work or to issue payment(s) to the District and/or its contractor(s).

- (iv) In the event the District takes over and satisfactorily completes the Work, if the unpaid balance of the Contract Amount exceeds the cost to the District of satisfactorily completing the Work, including, without limitation, compensation for any additional architectural, managerial or administrative services needed as a result of the Contractor's default, such excess shall be paid to the Contractor after satisfactory completion and acceptance of the Work by the District less any amounts attributable to any stop payment notices and amounts withheld by the District in accordance with applicable law or the Contract. If the cost to the District of satisfactorily completing the Work is greater than the unpaid balance of the Contract Amount, the Contractor, or its surety, shall pay the difference to the District within thirty days of notice from the District. In addition, the District may pursue any other recourse or remedies against the Contractor and/or its surety as may be available pursuant to law or the Contract.

**Section 10.4 Termination By Contractor.** Subject to the other provisions of this Section, the Contractor may stop the Work or initiate termination of the Contract by giving written notice to the District Representative if, through no fault of the Contractor or its employees, subcontractors or suppliers: (i) all work on the Project ceases for a period exceeding sixty days pursuant to an order or direction of any court or government entity, other than the District, with jurisdiction over any portion of the Project; (ii) the District Representative arbitrarily fails, within thirty days of receipt from Contractor of an applicable Progress Payment Application, to issue a certificate for payment for any undisputed amount(s) due to Contractor; or (iii) the District fails, within sixty days of receipt from the District Representative of a certificate of payment therefor, to pay to the Contractor any undisputed amount specified in such certificate of payment. Upon receipt of any such notice from the Contractor, the District shall have fifteen days to cure or make other arrangements for cure of the matter as are acceptable to the Contractor. If the District fails within the required time period to cure or make such acceptable arrangements for cure of the matter, the Contractor may stop the Work or terminate the Contract by giving additional written notice to the District, which notice shall be effective immediately upon receipt by the District. In the event the Contractor stops the Work or terminates the Contract pursuant to either subdivision (ii) or (iii) of the first sentence of this Section, the District shall be liable to the Contractor for any losses thereby reasonably incurred by the Contractor; provided that the Contractor shall not be entitled to recover any lost or foregone profits attributable to the portions of the Work not satisfactorily completed by the Contractor prior to stoppage of the Work or termination of the Contract.

## **PART 11. LAWS AND OTHER REQUIREMENTS.**

**Section 11.1 Liability for Non-Compliance with Laws.** The Contractor at all times during the execution of the Work shall be and shall remain fully informed of all local, State and federal laws, ordinances, rules, regulations or other requirements that may in any manner affect those engaged or employed to perform any of the Work or the materials used in performing the Work, or that may in any way affect the performance of the Work. In addition, the Contractor at all times during the execution of the Work shall be and shall remain fully informed of all rules, regulations, orders, and other requirements of any public or private entity with jurisdiction over the Work. In performing the Work,

the Contractor shall comply with, and give notices required pursuant to, all laws, ordinances, rules, regulations, and other requirements applicable to the Work as drawn and specified. The Contractor shall be liable for any violation of a law, ordinance, rule, regulation, or other requirement in connection with performance of the Work. If the Contractor observes that the Plans and Specifications in any respect do not conform with any applicable law, ordinance, rule, regulation or other requirement, the Contractor shall promptly notify the District Representative in writing. The Contractor shall bear all liability and costs, including any fines, arising from performance of any Work that the Contractor knew or reasonably should have known was contrary to any applicable law, ordinance, rule, regulation or other requirement, and the Contractor failed to notify the District Representative of the same a sufficient time in advance of performing the Work to permit the District to investigate and resolve the discrepancy.

**Section 11.2 Applicable Regulations.** The performance of the Work, including all construction and the materials and equipment used in connection with or incorporated into the Work, shall, not as a limitation, conform to all applicable requirements of the regulatory provisions specified in this Section. Each of such specified regulatory provisions, as those may be amended from time to time, is hereby incorporated as an operative part of the Plans and Specifications, and Contractor shall maintain a current copy of each at the Project Site. In the event of any conflict between the requirements of the various specified regulatory provisions, or in the event of any conflict between the requirements of the specified regulatory provisions and the requirements of any other applicable provision of law, the most authoritative requirements shall govern and nothing in the Contract Documents shall be construed to permit work that does not conform with such requirements. The Contractor shall not be entitled to additional compensation for any Changes in the Work necessary to ensure compliance with the requirements of the specified regulatory provisions, and the cost of any such Changes in the Work shall be deemed to be encompassed within the Contract Amount. The specified regulations are as follows:

- (i) Title 8 California Code of Regulations (Industrial Relations), Chapter 4 (Division of Industrial Safety), Subchapter 4 (Construction Safety Orders), commencing with Section 1500.
- (ii) Title 19 California Code of Regulations (Public Safety), Division 1 (State Fire Marshal), commencing with Section 1.00.
- (iii) Title 21 California Code of Regulations (Public Works), Division 1 (Department of General Services), Chapter 1 (Office of the State Architect), Subchapter 1 (Safety of Construction of Public Schools), commencing with Section 1.
- (iv) Title 24 California Code of Regulations (the California Building Standards Code).

**Section 11.3 Provisions Deemed Inserted.** Each and every provision or clause required by law to be inserted in the Contract are hereby deemed to have been inserted, and the Contract shall be interpreted and enforced as though such provisions and clauses are expressly set forth herein. If, through mistake or otherwise, any required provision is not inserted or is not correctly inserted, then upon written request of either the District or the Contractor, the Contract shall be amended to make the insertion or correction. Any and all references in the Contract to laws, ordinances, rules, regulations or other requirements shall be deemed and construed to include all amendments, replacements and enactments thereto that are in effect as of the date of the Contract, as well as any later amendments thereto that do not materially alter the rights or obligations of the Parties.

**Section 11.4 Equal Opportunity Employer.** The Contractor represents and warrants that it is an equal opportunity employer and that it shall not, in connection with the Work, discriminate against any employee or applicant for employment in violation of any applicable federal, State, or local law, including, without limitation, on the basis of such person's race, religion, color, national origin, ancestry, sex, or age. Such policy of non-discrimination shall apply to all activities related to recruitment advertising, recruitment, initial employment, promotion, demotion, transfer, and layoff or termination.

**Section 11.5 DVBE Participation.** If the Special Provisions provide that the Contractor must comply with the provisions of this Section, then the Contractor must, following completion of the Work and as a condition to Final Payment, complete, execute, and submit to the District the "Certification Regarding DVBE Participation" form included in the Required Contract Forms.

**Section 11.6 Tobacco-Free Facility.** All properties and facilities owned, leased or operated by the District, including the Project, are tobacco-free work places. It is strictly forbidden while on or in any District -controlled property or facility, including the Project, to smoke, chew, or otherwise use tobacco products. Any employee of the Contractor or its subcontractors found in violation of these requirements will be required to permanently leave District premises and the Contractor shall not thereafter re-employ such person on the Project or permit such person on the Project Site. The Contractor shall include this provision in all contracts with subcontractors and others performing any of the Work or providing labor, materials or services related to the Work, and each shall provide a copy of this provision to its employees on the Project.

**Section 11.7 Drug-Free Facility.** All properties and facilities owned, leased or operated by the District, including the Project, are drug-free work places. It is strictly forbidden while on or in any District -controlled property or facility to: (i) engage in the unlawful manufacture, dispensation, possession or use, including being under the influence, of any controlled substance; (ii) possess or use any alcoholic beverage; or (iii) use any illegal substance which may cause significant impairment of normal abilities. Any employee of the Contractor or its subcontractors found in violation of these requirements will be required to permanently leave District premises and the Contractor shall not thereafter re-employ such person on the Project or permit such person on the Project Site. The Contractor shall include this provision in all contracts with subcontractors and others performing any of the Work or providing labor, materials or services related to the Work, and each, as well as the Contractor, shall provide a copy of this provision to its employees on the Project.

**Section 11.8 Compliance with Labor Code Requirements.** The Project is a "public works project" as defined in Section 1720 of the California Labor Code ("Labor Code") and, therefore, Part 7, Chapter 1, of the Labor Code is applicable to the Project. The Contractor must be, and shall be deemed and construed to be, aware of and understand the requirements of Labor Code Sections 1720 *et seq.* and 1770 *et seq.*, and Title 8 of the California Code of Regulations, Section 16000 *et seq.* (collectively, "Labor Laws"), which require the payment of prevailing wage rates and the performance of other acts in connection with public works projects. The Contractor acknowledges that the Project is subject to compliance monitoring and enforcement by the DIR. In any event, the Contractor, at no additional cost to the District, must comply with any and all applicable Labor Law requirements, including, without limitation, requirements for payment of Prevailing Wages, maintenance, inspection and submittal of payroll records, notice and posting requirements, *et cetera*. The Contractor must ensure that any and all subcontractors working under the Contractor comply with the Labor Laws and other public works requirements. The Contractor, at no additional cost to the District, must cooperate with the DIR, and the District in connection with Labor Law compliance matters. A contractor or subcontractor that has been debarred in accordance with the Labor Code, including, without limitation, pursuant to Sections 1777.1 or 1777.7, is not eligible to bid on, perform, or contract to perform any portion of the Work.

Wage rates for the Work shall be in accordance with the general prevailing rates of per-diem wages determined by the Director of Industrial Relations pursuant to Labor Code Section 1770. Wage rates shall conform to those on file at the District's principal office, which are available for review upon request, and posted at the Project Site. The District will withhold payment to the Contractor necessary to satisfy civil wage and penalty assessment issued by the Labor Commissioner. The following Labor Code sections are by this reference incorporated into and are a fully operative part of the Contract, and Contractor shall be solely responsible for compliance therewith:

- (i) Section 1735: Anti-Discrimination Requirements;
- (ii) Section 1775: Penalty for Prevailing Wage Rate Violations;
- (iii) Section 1776: Payroll Records;
- (iv) Sections 1777.5, 1777.6 and 1777.7: Apprenticeship Requirements;
- (v) Sections 1810 through 1812: Working Hour Restrictions;
- (vi) Sections 1813 and 1814: Penalty for Failure to Pay Overtime; and
- (vii) Section 1815: Overtime Pay.

**Section 11.9 Requirements for Payroll Records.** The Contractor must comply with all applicable provisions of Labor Code Section 1776, which relates to preparing and maintaining accurate payroll records, and submitting or making such payroll records available for review and copying by the District, the DIR's Division of Labor Standards Enforcement, and Division of Apprenticeship Standards. The payroll records must be certified, maintained at the principal offices of the Contractor, and submitted or made available as required by Labor Code Section 1776. The Contractor must inform the District of the location at which the payroll records are kept, including the street address, city and county, and must, within five working days, provide notice to the District of any change in such location. If the Contractor or any subcontractor fails to timely comply with requests for certified payroll records, it shall forfeit, as a penalty to the District, \$100 for each calendar day, or portion thereof, for each worker, until strict compliance is effectuated, and, in addition to penalties as provided by law, may be subject to debarment pursuant to Labor Code Section 1771.1. Timely provision by the Contractor of certified payroll records also shall be a condition precedent to the District's obligation to make any subsequent progress, final, Retention, or other payments to the Contractor pursuant to the Contract.

**Section 11.10 Registration with DIR.** If, at any time during the Project, the Contractor intends to use a subcontractor that was not listed in its bid (e.g., a subcontractor performing work costing less than one-half of one percent of the Contractor's total bid amount), then, before the subcontractor performs any work on the Project, the Contractor must provide written notice to the District that identifies the subcontractor and includes evidence that the subcontractor is properly registered with the DIR. The Contractor shall be responsible for monitoring the registration status of its subcontractors at all times during the course of the Project, and in the event any subcontractor is or becomes not duly registered, the Contractor shall: (i) prohibit the subcontractor from working on the Project; and (ii) provide written notice to the District informing the District of the subcontractor's registration status. Notwithstanding anything to the contrary, if at any time during the performance of the Work, the Contractor or any of its subcontractors is not duly registered pursuant to Labor Code Section 1725.5 (including, without limitation, if the registration expires or the DIR revokes the registration), then: (i) the District in its sole discretion may cancel the Contract and/or replace the Contractor or subcontractor with a contractor or subcontractor that is duly registered pursuant to Labor Code Section 1725.5; and (ii) the Contractor and/or subcontractor may be subject to penalties imposed by the DIR.

**Section 11.12 Penalties for Violations of Labor Laws.** In accordance with Labor Code Section 1775, the Contractor shall forfeit, as a penalty to the District, not more than \$200 and, subject to limited exceptions, not less than certain amounts specified by law, for each calendar day, or portion thereof, for

each worker paid less than prevailing wage rates as determined by the director of the DIR. The Contractor shall pay to each worker the difference between such stipulated prevailing wage rate and the amount paid to the worker for each calendar day or portion thereof for which the worker was paid less than the applicable prevailing wage rates.

**Section 11.13 Assignment of Anti-Trust Claims.** In accordance with Public Contract Code Section 7103.5, the Contractor, in entering into the Contract, hereby offers and agrees to assign to the District all rights, title, and interest in and to all causes of action Contractor may have under Section 4 of the Clayton Act (15 U.S.C. Section 15) or under the Cartwright Act (Chapter 2, commencing with Section 16700, of Part 2 of Division 7 of the Business and Professions Code) arising from purchases of goods, services, or materials pursuant to the Contract. Such assignment shall be made and become effective at the time the District tenders Final Payment to the Contractor, without further acknowledgment by the Parties.

## **PART 12. DISPUTE RESOLUTION.**

**Section 12.1 Governing Law and Venue.** The Contract and all rights and obligations arising out of it shall be construed in accordance with the laws of the State. Any arbitration, litigation or other proceeding arising out of the Contract shall be commenced and conducted only in the County of San Diego, California.

**Section 12.2 Mediation and Arbitration.** The provisions of Public Contract Code Section 9204, and, to the extent applicable, Public Contract Code Section 20104 *et seq.* (collectively, the "Dispute Resolution Provisions") shall apply to Contractor claims arising or resulting from the Contract (each a "Claim"). The Dispute Resolution Provisions are incorporated herein by this reference. The Dispute Resolution Provisions require that any such Claim be in writing, served by registered mail or certified mail with return receipt requested, and supported by reasonable documentation of the basis for the Claim. To the extent provided in Public Contract Code Section 9204, the Contractor may file Claims on behalf of its subcontractors of any tier. The Contractor must file any and all claims prior to submitting to the District an invoice for Final Payment for the Work. The District shall respond in writing to each Claim within forty-five days and shall pay any undisputed portion of the Claim as required pursuant to the Dispute Resolution Provisions. If the Contractor disputes the District's response to a Claim, or the District does not timely respond to a Claim, the Contractor may submit to the District a written demand to meet and informally confer regarding settlement of the Claim. In such event, the District shall schedule such meeting to occur within thirty days following receipt by the District of the written demand. If, following such meeting, any portion of the Claim remains in dispute, the Parties shall submit the Claim to non-binding mediation as required by the Dispute Resolution Provisions. If a claim for \$375,000 or less remains in dispute following such mediation, and a civil action is commenced to resolve the Claim, judicial arbitration shall be required pursuant to Public Contract Code Section 20104.4. The Contractor should review Public Contract Code Sections 9204 and 20104 *et seq.* if the Contractor desires additional details regarding the Dispute Resolution Provisions.

**Section 12.3 Costs and Expenses.** With respect to any applicable mediation or arbitration, the Parties shall initially pay equal shares of any and all associated mediator or arbitrator fees; however, the prevailing Party in any such proceeding shall be entitled to recover such initial costs, in addition to other costs as specified herein, as an item of damage and/or recoverable cost. Notwithstanding the foregoing or anything else, each Party shall in all cases be responsible for paying its own attorneys' fees and other legal costs, including, without limitation, in connection with any mediation, arbitration, and/or litigation arising from the Contract.

**Section 12.4 Continuation of Work.** Notwithstanding anything in the Contract Documents to the contrary, in the event of any dispute between the District and the Contractor, or any dispute between the Contractor and any subcontractor or other third party, the Contractor shall not be permitted to cease performance of the Work, but the Contractor shall have the right to pursue all other remedies permitted pursuant to the Contract and applicable law. A violation of this provision by the Contractor shall constitute a material breach of the Contract.

**EXHIBIT A**

**STRUCTURAL CALCULATIONS  
FOR  
SKYLINE ELEMENTARY SCHOOL  
BASEBALL NETTING  
STRUCTURAL CALCULATION  
SOLONA BEACH, CA**

**KNA No. 430.001**

**DECEMBER. 2020**

**Prepared Under the Direction of:**



---

**Kevin Westervelt**

**Registered Structural Engineer, S.E. 5681 (CA)**



9931 Muirlands Blvd., Irvine, CA 92618  
Tel (949) 462-3200 • Fax (949) 462-3201  
[www.KNAstructural.com](http://www.KNAstructural.com)



**SKYLINE ELEMENTARY SCHOOL  
BASEBALL NETTING  
SOLONA BEACH, CA**

The calculations presented herewith represent the following designs as described:

- Pole and Footing design for Baseball Netting

**SKYLINE ELEMENTARY SCHOOL,  
BASEBALL NETTING  
SOLONA BEACH, CALIFORNIA**

**Description**

**Pages**

Netting Loads

Page 1

Sag Tension Calculation

Page 2

Wind Load

Page 4

Tension Load

Page 6

Deflection Check & Stress Check

Page 8

Footing Analysis

Page 11

- > Total Area covered by 4 poles = 572 sq. ft
- > Max Netting Weight on Each pole =  $572 \text{ Sq ft} / (4 \text{ poles} \times 75 \text{ sqft/\#}) = 2 \#$
- > #15 Twine Size = 0.052". Closed area % =  $2 \times 0.052" / 1.75" = 6\% \text{ closed} \times \text{Trib Area of Netting (for Wind pressure calculation)}$

## Netting Weight

### Net Construction

### Netting Weight Chart

(Ratio 29.3%) when height and length of mesh are the same, or on square mesh.  
Netting is treated with black plastic.

Twine Size	7/8" Sq.	1" Sq.	1½" Sq.	1¾" Sq.	1 7/8" Sq.	2" Sq.	2½" Sq.	3" Sq.	3½" Sq.	4" Sq.
#9	46	55	92	111	120	129	166	206	245	283
#15	29	36	60	72	78	85	109	136	162	187
#18	20	24	41	50	54	59	77	96	115	133
#21	15	19	32	39	42	46	61	76	91	106
#30	n/a	n/a	22	27	30	32	42	53	64	74
#36	n/a	11.5	20	24	26	28	37	46	55	64
#42	n/a	n/a	17	21	23	25	33	41	49	57
#60	n/a	n/a	10	12	13	14	19	23	28	33
#96	n/a	n/a	4.5	5.8	6.4	7	9.5	12.2	15	18

**HOW TO READ CHART:** Above is for maximum **square feet per pound of netting** .

As the height or length of the mesh get further apart the square feet per pound becomes less.

#### Common mesh size applications:

Golf driving nets are #21 netting, 7/8" square mesh.

Golf screen nets are #9 netting, 1" square mesh.

Hockey and LaCrosse nets are #30 netting, 1-1/2" square mesh.

BB/SB, outfield protection nets are #15 netting, 1-3/4" square mesh.

BB/SB, infield protection nets are #21, #30, or #36 netting, 1-7/8" square mesh.

BB/SB, personal use batting cages are #15 netting, 1-3/4" square mesh.

BB/SB, little league and light use batting cages are #21 netting, 1-7/8" square mesh.

BB/SB, high school batting cages are #30 or #36 netting, 1-7/8" square mesh.

BB/SB, college batting cages are #36 or #42 netting, 1-7/8" square mesh.

BB commercial batting cages, low impact areas, are #42 netting, 1-7/8" square mesh.

BB commercial batting cages, high impact areas, are #60 or #96 netting, 1-7/8" square mesh.

BB professional batting cages are #42, #60, or #96 netting, 1-7/8" square mesh.

Larege ball barrier nets are #21 or #36 netting, 4" square mesh.

## SAG TENSION CALCULATION FOR NETTING ON POLES

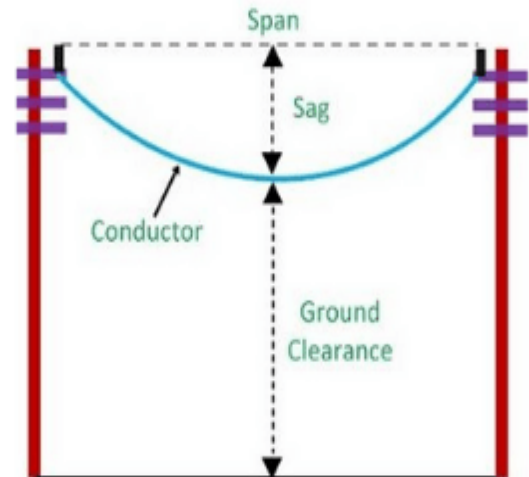
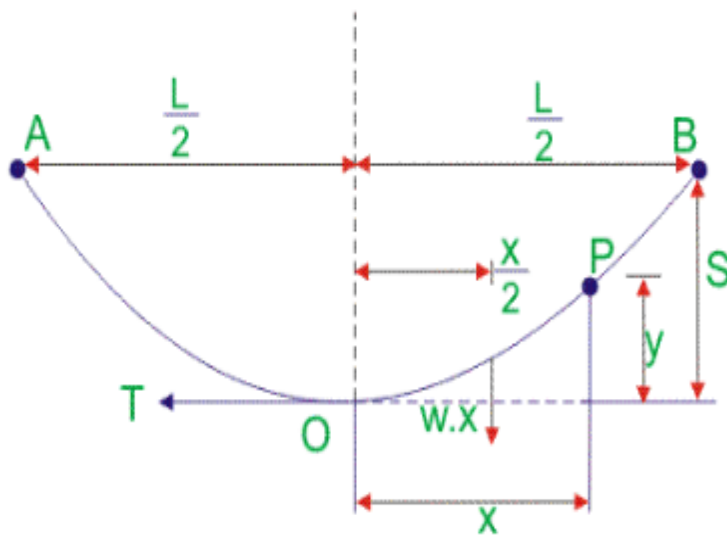

Suppose, AOB is the conductor. A and B are points of supports. Point O is the lowest point and the midpoint.

Let,  $L$  = length of the span, i.e. AB

$w$  is the weight per unit length of the conductor

$T$  is the tension in the conductor.

We have chosen any point on the conductor, say point P.

The distance of point P from the Lowest point O is  $x$ .

$y$  is the height from point O to point P.

Equating two moments of two forces about point O as per the figure above we get,

$$Ty = wx \times \frac{x}{2}$$

$$\text{Now, } y = \frac{wx^2}{2T}, \text{ when } y = S \text{ and } x = L/2$$

$$\text{Then } S = \frac{wL^2}{8T}$$

$w_w$  is the force of wind per unit length

$w_w = \text{wind pressure per unit area} \times \text{projected area per unit length}$

$$= \text{wind pressure} \times [(d + 2t) \times 1]$$

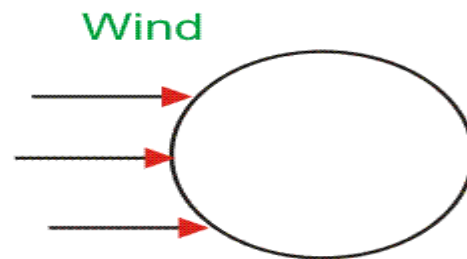

So, the total weight of the conductor per unit length is

$$w_t = \sqrt{(w + w_i)^2 + (w_w)^2}$$

$$\text{And } \tan \theta = \frac{w_w}{w + w_i}$$

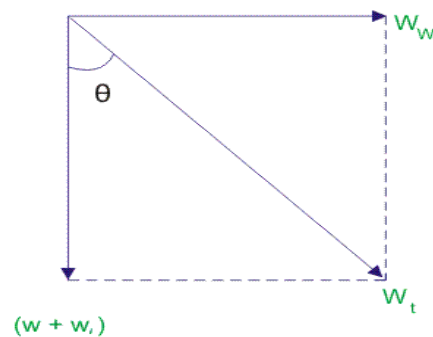

The sag in the conductor is given by

$$S = \frac{w_t L^2}{2T}$$

So the vertical sag

$$S_v = S \cos \theta$$



PROJECT SKYLINE ES  
BASEBALL NETTING  
 CLIENT \_\_\_\_\_

SHEET \_\_\_\_\_ OF \_\_\_\_\_  
 JOB NO 430,001  
 DATE 12/20  
 BY RT

\* DESIGN WIND LOADS : OTHER STRUCTURES

$F = q_z G C_f A_f$  (lb) (ASCE 7-16, E0 29.4-1)

$q_z = 0.00256 K_z K_{zt} K_e K_d V^2$  , V in m/h (26.10-1)

$V = 96$  mph  $G = 0.85$  (26.11)

$K_z = 0.92$  (case 1 : 22') , Table 26.10-1

$= 0.86$  (case 11, : 16') , Table 26.10-1

$K_{zt} = 1, K_d = 0.85, K_e = 1$

$q_{z1} = 0.00256 \times 0.92 \times 0.85 \times 1 \times 1 \times 96^2 = 18.5$  psf (case 1)

$q_{z2} = 0.00256 \times 0.86 \times 0.85 \times 1 \times 1 \times 96^2 = 17.2$  psf (case 11)

$C_f = 1.5$  (Figure 29.4-2) - conservative.

$F = q_z G C_f$  (lb/ft) - considering width = 1'  
 (pole = 8" - conservative)

$P_1 = 0.6 \times 18.5 \times 0.85 \times 1.5 = \boxed{14.15}$  psf (case 1, h = 22')  
 (ASD) ( $q_z$ ) ( $G$ ) ( $C_f$ ) (ASD)

$P_2 = 0.6 \times 17.2 \times 0.85 \times 1.5 = \boxed{13.16}$  psf (case 2, h = 16')

THESE CALCULATIONS CONTAIN INFORMATION PROPRIETARY TO KNA STRUCTURAL ENGINEERS, INC. THIS DOCUMENT OR ITS CONTENTS MAY NOT BE REPRODUCED OR DISCLOSED TO OTHERS WITHOUT THE PRIOR WRITTEN CONSENT OF KNA STRUCTURAL ENGINEERS, INC. ALL RIGHTS RESERVED.

CLIENT NO.

REVIEWED BY

DATE

PROJECT SKYLINE ES  
BASEBALL NETTING  
CLIENT \_\_\_\_\_

SHEET \_\_\_\_\_ OF \_\_\_\_\_  
JOB NO 430.001  
DATE 12/20  
BY RT

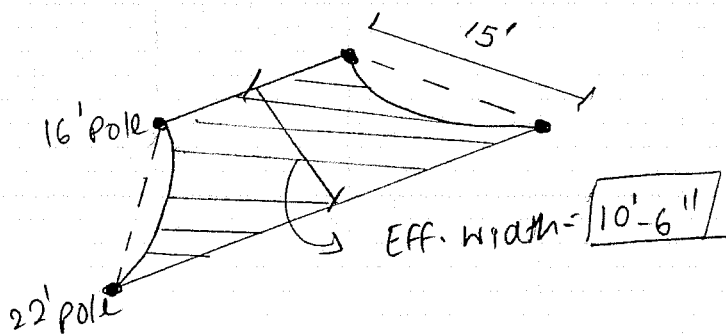

SLOPE FACTOR (SF)  
 $\theta = \tan^{-1} \left( \frac{\text{difference in height}}{\text{distance bet}^n \text{ poles}} \right)$

$\theta = \tan^{-1} \left( \frac{22' - 16'}{10.5'} \right)$

$\approx 30^\circ$

SF =  $\frac{1}{\cos \theta} = 1.15$   
 (15' increase in horizontal plan area)

Centroid

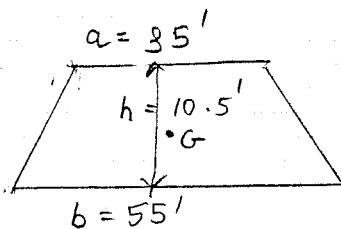

$G = \frac{b + 2a}{3(a+b)} h$   
 $= \frac{55' + 2(35')}{3(35' + 55')} h = 0.46h$

$F_1 = 0.06 \times (14.15 \text{ psf}) \times 0.46 \times 10.5' \times 1.15 \text{ (SF)} = 4.72 \text{ PLF}$   
 ↳ 1. opening      ↳ centroid      ↳ Net width

$F_2 = 0.06 \times (13.16 \text{ psf}) \times 0.54 \times 10.5' \times 1.15 = 5.15 \text{ PLF}$

considering forces in orthogonal direction.

Net  $F_1$  (wind) =  $4.72 + 0.3 \times 5.15 = 6.27 \text{ PLF}$   
 (30%.)

$F_2$  (wind) =  $5.15 + 0.3 \times 4.72 = 6.57 \text{ PLF}$

Force due to Dead load of Netting = 0.25 PLF (conservative)

CLIENT NO. \_\_\_\_\_

REVIEWED BY \_\_\_\_\_

DATE \_\_\_\_\_

PROJECT Skylime  
 CLIENT \_\_\_\_\_

SHEET \_\_\_\_\_ OF \_\_\_\_\_  
 JOB NO \_\_\_\_\_  
 DATE 1/21  
 BY RT

\* Wmd load calc due to chain link fence (pole 2, H = 22')

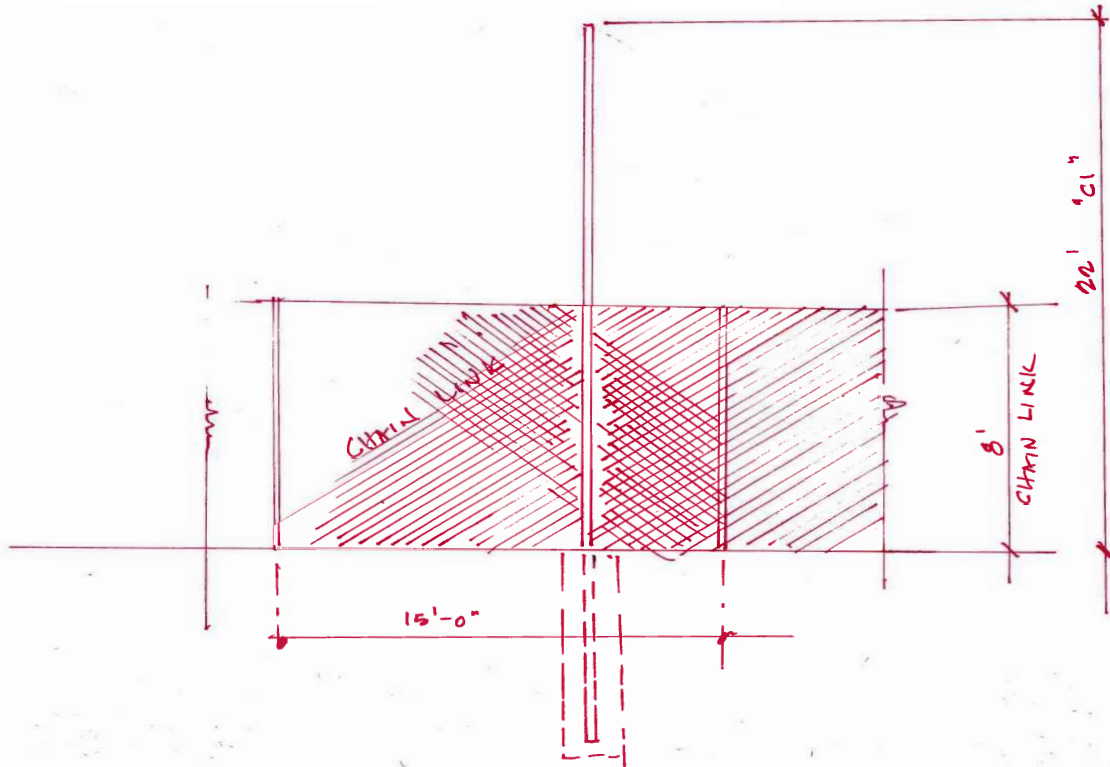

$$F = (\% \text{ of closure}) \times (P_{\text{wmd}}) \times L \times H$$

chainlink-wmd

$$= 0.14 \times (13.16 \text{ psf}) \times \frac{15'}{2} \times 8' = 110.5 \#$$

(9 gauge link)  
 force across span of netting

$$w_{\text{CL}} = \frac{110.5 \#}{\left(\frac{55'}{2}\right)} = 4.09 \text{ p/f.}$$

CLIENT NO. \_\_\_\_\_

REVIEWED BY \_\_\_\_\_

DATE \_\_\_\_\_





PROJECT Skyline ES  
Baseball Netting

CLIENT \_\_\_\_\_

SHEET \_\_\_\_\_ OF \_\_\_\_\_  
JOB NO 430.001  
DATE 12/20  
BY RT

Case 1  $H = 22'$

$$S = \frac{w_E L^2}{2T} \quad , (\text{max sag, } \cos\theta = 1)$$

$$w_E = w_{CL} + \sqrt{w^2 + w_w^2} = 4.09 + \sqrt{0.25^2 + 6.27^2} = 10.37 \text{ plf}$$

$L = 55'$  (max distance between 2 poles)

Limiting Sag  $S = 3'$  (max)

$$T_1 = \frac{w_E L^2}{2S} = \frac{10.37 \text{ plf} \times 55^2}{2 \times 3'} = \boxed{5228 \#}$$

(To check pole embedment & pole deflection)

Case II:  $H = 16'$

$$S = \frac{w_E L^2}{2T} \quad , (\text{max sag, } \cos\theta = 1)$$

$$w_E = \sqrt{w^2 + w_w^2} = \sqrt{0.25^2 + 6.57^2} = 6.58 \text{ plf}$$

$L = 35'$  (max distance between 2 poles)

Limiting Sag  $S = 3'$  (max)

$$T_2 = \frac{w_E L^2}{2S} = \frac{6.58 \text{ plf} \times 35^2}{2 \times 3'} = \boxed{11343 \#}$$

(To check pole embedment & pole deflection)

Net Tension for Erection (Dead Load only)

$$T_1 = \frac{0.25 \text{ plf} \times 55^2}{2 \times 1'} = \boxed{378 \#}$$

(Restricting sag to 1' During pole erection)

$$T_2 = \frac{0.25 \text{ plf} \times 35^2}{2 \times 1'} = \boxed{153 \#}$$

CLIENT NO.

REVIEWED BY

DATE



PROJECT Skyline ES  
Baseball Nitting  
 CLIENT \_\_\_\_\_

SHEET \_\_\_\_\_ OF \_\_\_\_\_  
 JOB NO 430-001  
 DATE 12/20  
 BY RT

\* Deflection check (governing check for pipe diameter)

$$\Delta_{\text{limit}} = \frac{2L}{120} \quad C_1: \quad L = 22' \quad \Delta_{\text{lim}} = \frac{2 \times 22' \times 12''}{120} = 4.4''$$

$$C_2: \quad L = 16' \quad \Delta_{\text{lim}} = \frac{2 \times 16' \times 12''}{120} = 3.2''$$

$$P_1 = 0.42 T_1 (CBC, 1604.3) \Rightarrow P_1 = 0.42 \times 5228 = 2196$$

$$\text{Case 1: } \Delta = \frac{PL^3}{3EI}$$

$$4.4'' = \frac{2196 \# \times (22' \times 12'')^3}{3 \times (35 \times 10^6 \text{ PSI}) \times I_{\text{reqd}}}$$

$$I_{\text{reqd}} = 185 \text{ m}^4 \quad \text{USE } 10'' \text{ PIPE, } I = 151 \text{ m}^4$$

$$\text{OR HSS } 10 \times 0.5, I = 159 \text{ m}^4$$

$$\text{Case II: } \Delta = \frac{PL^3}{3EI}$$

$$P_2 = 0.42 T_2 = 0.42 \times 1343 = 564 \#$$

$$3.2'' = \frac{564 \# \times (16' \times 12'')^3}{3 \times (35 \times 10^6 \text{ PSI}) \times I_{\text{reqd}}}$$

$$I_{\text{reqd}} = 11.88 \text{ m}^4 \quad \text{USE } 8'' \text{ PIPE, } I = 68 \text{ m}^4$$

$$\text{OR HSS } 8.75 \times 0.322, I = 68 \text{ m}^4$$

CLIENT NO.

REVIEWED BY

DATE

**Steel Beam**

File: Gravity Design.ec6  
Software copyright ENERCALC, INC. 1983-2020, Build:12.20.8.17  
KNA STRUCTURAL ENGINEERS, INC.

Lic. #: KW-06002873

**DESCRIPTION:** POLE STRESS CHECK 22'

**CODE REFERENCES**

Calculations per AISC 360-16, IBC 2018, CBC 2019, ASCE 7-16  
Load Combination Set : ASCE 7-16

**Material Properties**

Analysis Method : Allowable Strength Design	Fy : Steel Yield : 42.0 ksi
Beam Bracing : Completely Unbraced	E: Modulus : 35,000.0 ksi
Bending Axis : Major Axis Bending	

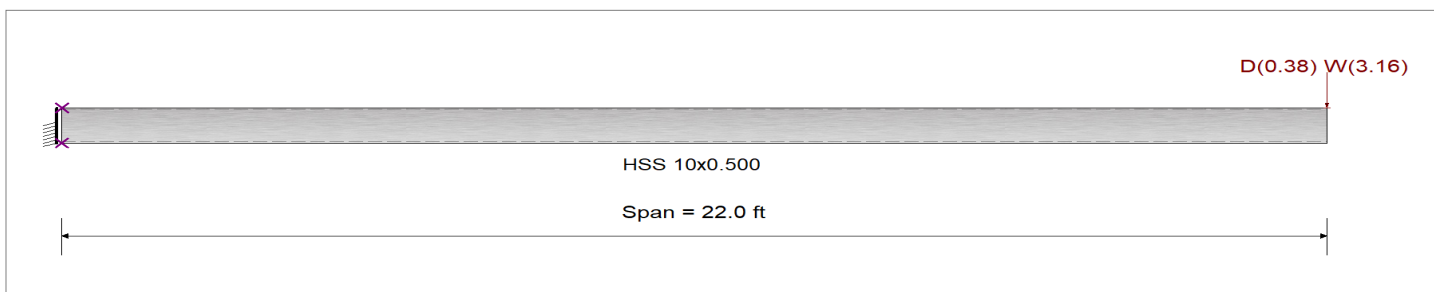

**Applied Loads**

Service loads entered. Load Factors will be applied for calculations.

Beam self weight calculated and added to loading  
Load(s) for Span Number 1  
Point Load : D = 0.380, W = 3.160 k @ 22.0 ft

**OK FOR FLEXURE.  
REFER PREVIOUS PAGES FOR  
DEFLECTION CHECKS**

**DESIGN SUMMARY**

**Design N.G.**

Maximum Bending Stress Ratio =	<b>0.703</b> : 1	Maximum Shear Stress Ratio =	<b>0.032</b> : 1
Section used for this span	<b>HSS 10x0.500</b>	Section used for this span	<b>HSS 10x0.500</b>
Ma : Applied	62.361 k-ft	Va : Applied	3.393 k
Mn / Omega : Allowable	88.653 k-ft	Vn/Omega : Allowable	104.874 k
Load Combination	<b>+D+0.60W</b>	Load Combination	<b>+D+0.60W</b>
Location of maximum on span	0.000ft	Location of maximum on span	0.000 ft
Span # where maximum occurs	Span # 1	Span # where maximum occurs	Span # 1
<b>Maximum Deflection</b>			
Max Downward Transient Deflection	3.475 in	Ratio =	<b>151</b> <360
Max Upward Transient Deflection	0.000 in	Ratio =	<b>0</b> <360
Max Downward Total Deflection	2.964 in	Ratio =	<b>178</b> <180
Max Upward Total Deflection	0.000 in	Ratio =	<b>0</b> <180

**Maximum Forces & Stresses for Load Combinations**

Load Combination	Segment Length	Span #	Max Stress Ratios		Summary of Moment Values						Summary of Shear Values			
			M	V	Mmax +	Mmax -	Ma Max	Mnx	Mnx/Omega	Cb	Rm	Va Max	Vnx	Vnx/Omega
D Only	Dsgn. L = 22.00 ft	1	0.233	0.014		-20.65	20.65	148.05	88.65	1.00	1.00	1.50	175.14	104.87
+D+0.60W	Dsgn. L = 22.00 ft	1	0.703	0.032		-62.36	62.36	148.05	88.65	1.00	1.00	3.39	175.14	104.87
+D+0.450W	Dsgn. L = 22.00 ft	1	0.586	0.028		-51.93	51.93	148.05	88.65	1.00	1.00	2.92	175.14	104.87
+0.60D+0.60W	Dsgn. L = 22.00 ft	1	0.610	0.027		-54.10	54.10	148.05	88.65	1.00	1.00	2.79	175.14	104.87
+0.60D	Dsgn. L = 22.00 ft	1	0.140	0.009		-12.39	12.39	148.05	88.65	1.00	1.00	0.90	175.14	104.87

**Overall Maximum Deflections**

Load Combination	Span	Max. "-" Defl	Location in Span	Load Combination	Max. "+" Defl	Location in Span
W Only	1	3.4752	22.000		0.0000	0.000

**Vertical Reactions**

Load Combination	Support 1	Support 2
Overall MAXimum	3.393	
Overall MINimum	0.898	
D Only	1.497	
+D+0.60W	3.393	
+D+0.450W	2.919	

Support notation : Far left is #1

Values in KIPS

**Steel Beam**

File: Gravity Design.ec6  
Software copyright ENERCALC, INC. 1983-2020, Build:12.20.8.17  
KNA STRUCTURAL ENGINEERS, INC.

Lic. #: KW-06002873

**DESCRIPTION:** POLE STRESS CHECK 16'

**CODE REFERENCES**

Calculations per AISC 360-16, IBC 2018, CBC 2019, ASCE 7-16  
Load Combination Set : ASCE 7-16

**Material Properties**

Analysis Method : Allowable Strength Design	Fy : Steel Yield : 42.0 ksi
Beam Bracing : Completely Unbraced	E: Modulus : 35,000.0 ksi
Bending Axis : Major Axis Bending	

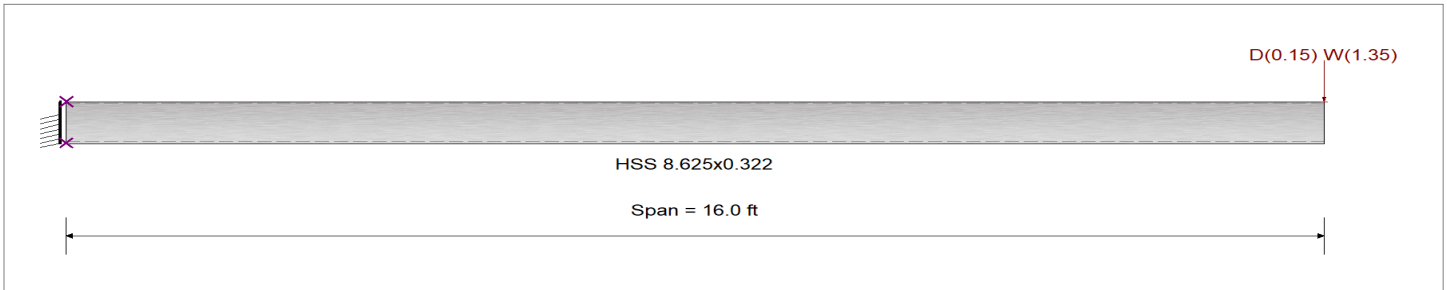

**Applied Loads**

Service loads entered. Load Factors will be applied for calculations.

Beam self weight calculated and added to loading  
Load(s) for Span Number 1  
Point Load : D = 0.150, W = 1.350 k @ 16.0 ft

**OK FOR FLEXURE.  
REFER PREVIOUS PAGES FOR  
DEFLECTION CHECKS**

**DESIGN SUMMARY**

**Design N.G.**

Maximum Bending Stress Ratio =	<b>0.436</b> : 1	Maximum Shear Stress Ratio =	<b>0.024</b> : 1
Section used for this span	<b>HSS 8.625x0.322</b>	Section used for this span	<b>HSS 8.625x0.322</b>
Ma : Applied	19.018 k-ft	Va : Applied	1.417 k
Mn / Omega : Allowable	43.593 k-ft	Vn/Omega : Allowable	59.228 k
Load Combination	<b>+D+0.60W</b>	Load Combination	<b>+D+0.60W</b>
Location of maximum on span	0.000ft	Location of maximum on span	0.000 ft
Span # where maximum occurs	Span # 1	Span # where maximum occurs	Span # 1
<b>Maximum Deflection</b>			
Max Downward Transient Deflection	1.333 in	Ratio =	<b>287</b> <360
Max Upward Transient Deflection	0.000 in	Ratio =	<b>0</b> <360
Max Downward Total Deflection	1.118 in	Ratio =	<b>344</b> >=180
Max Upward Total Deflection	0.000 in	Ratio =	<b>0</b> <180

**Maximum Forces & Stresses for Load Combinations**

Load Combination	Segment Length	Span #	Max Stress Ratios		Summary of Moment Values						Summary of Shear Values			
			M	V	Mmax +	Mmax -	Ma Max	Mnx	Mnx/Omega	Cb	Rm	Va Max	Vnx	Vnx/Omega
D Only	Dsgn. L = 16.00 ft	1	0.139	0.010		-6.06	6.06	72.80	43.59	1.00	1.00	0.61	98.91	59.23
+D+0.60W	Dsgn. L = 16.00 ft	1	0.436	0.024		-19.02	19.02	72.80	43.59	1.00	1.00	1.42	98.91	59.23
+D+0.450W	Dsgn. L = 16.00 ft	1	0.362	0.021		-15.78	15.78	72.80	43.59	1.00	1.00	1.21	98.91	59.23
+0.60D+0.60W	Dsgn. L = 16.00 ft	1	0.381	0.020		-16.59	16.59	72.80	43.59	1.00	1.00	1.17	98.91	59.23
+0.60D	Dsgn. L = 16.00 ft	1	0.083	0.006		-3.63	3.63	72.80	43.59	1.00	1.00	0.36	98.91	59.23

**Overall Maximum Deflections**

Load Combination	Span	Max. "-" Defl	Location in Span	Load Combination	Max. "+" Defl	Location in Span
W Only	1	1.3334	16.000		0.0000	0.000

**Vertical Reactions**

Load Combination	Support 1	Support 2
Overall MAXimum	1.417	
Overall MINimum	0.364	
D Only	0.607	
+D+0.60W	1.417	
+D+0.450W	1.215	

Support notation : Far left is #1

Values in KIPS

PROJECT SKYLINE ELEMENTARY SCHOOL  
BASEBALL NETTING  
 CLIENT O

SHEET \_\_\_\_\_ OF \_\_\_\_\_  
 JOB NO 430.001  
 DATE 12/20  
 BY RT

FLAGPOLE FOOTING DESIGN

NON-CONSTRAINED FLAGPOLE FOOTING DESIGN PER 2016 CBC, CHAPTER 18A

DEPTH OF EMBEDMENT,  $d = \frac{A}{2} \left( 1 + \sqrt{1 + \frac{4.36h}{A}} \right)$  (Equation 18A-1)

WHERE:

$A = \frac{2.34P}{S_b}$

- $b$  = DIAMETER OF FOOTING : 2.5 ft
- $h$  = HEIGHT OF APPLICATION OF LOAD : 22 ft
- $P$  = APPLIED LATERAL FORCE : 3136 # (ASD, 0.6T1= 0.6x5228)
- $S_1$  = ALLOWABLE LATERAL SOIL BEARING : 1.333Pp(d/3) psf  
 PRESSURE BASED ON DEPTH = 1/3d
- $P_p$  = BASIC ALLOWABLE LATERAL SOIL BEARING PRESSURE : 200 pcf (SEE NOTE BELOW)

NOTE: 1/2" GROUND MOTION IS PERMITTED, THEREFORE USE TWO TIMES THE ALLOWABLE LATERAL SOIL BEARING PRESSURE

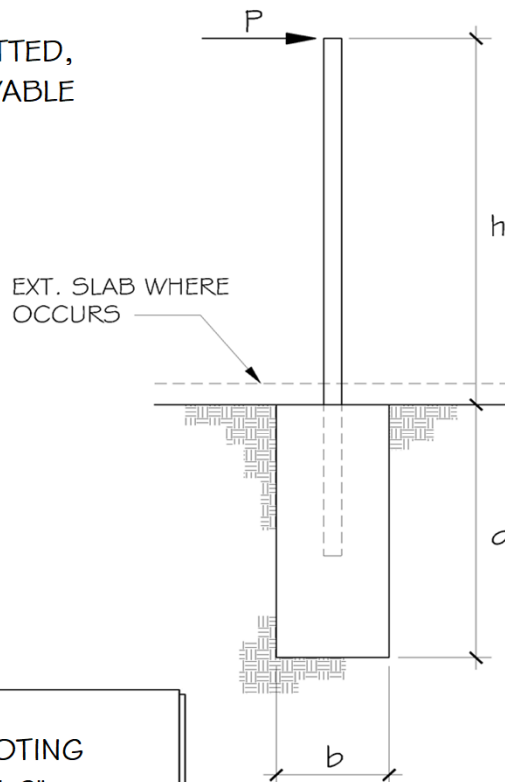

ITERATING "A" AND "d" YIELDS:

FOR  $d = 10.44$  ft:  
 $S_1 = 927.5$  psf  
 $A = 3.16$

PROVIDE 2'-6" DIAMETER POLE FOOTING WITH MINIMUM EMBEDMENT = 10'-6"

CLIENT NO. \_\_\_\_\_

REVIEWED BY \_\_\_\_\_

DATE \_\_\_\_\_

THESE CALCULATIONS CONTAIN INFORMATION PROPRIETARY TO KNA CONSULTING ENGINEERS, INC. THIS DOCUMENT OR ITS CONTENTS MAY NOT BE REPRODUCED OR DISCLOSED TO OTHERS WITHOUT THE PRIOR WRITTEN CONSENT OF KNA CONSULTING ENGINEERS, INC. ALL RIGHTS RESERVED.

PROJECT	SKYLINE ELEMENTARY SCHOOL	SHEET	_____	OF	_____
	BASEBALL NETTING	JOB NO	430.001		
CLIENT	O	DATE	12/20		
		BY	RT		

### FLAGPOLE FOOTING DESIGN

NON-CONSTRAINED FLAGPOLE FOOTING DESIGN PER 2016 CBC, CHAPTER 18A

DEPTH OF EMBEDMENT,

(Equation 18A-1)

WHERE:

$b$ = DIAMETER OF FOOTING	: 2.5 ft
$h$ = HEIGHT OF APPLICATION OF LOAD	: 16 ft
$P$ = APPLIED LATERAL FORCE	: 806 # (ASD = 0.6T1 = 0.6x 1343)
$S_1$ = ALLOWABLE LATERAL SOIL BEARING PRESSURE BASED ON DEPTH = $\frac{1}{3}d$	: 1.333 $P_p(d/3)$ psf
$P_p$ = BASIC ALLOWABLE LATERAL SOIL BEARING PRESSURE	: 200 pcf (SEE NOTE BELOW)

NOTE: 1/2" GROUND MOTION IS PERMITTED,  
THEREFORE USE TWO TIMES THE ALLOWABLE  
LATERAL SOIL BEARING PRESSURE

ITERATING "A" AND "d" YIELDS:

FOR  $d = 5.82$  ft:

$$S_1 = 517.5 \text{ psf}$$

$$A = 1.46$$

PROVIDE 2'-6" DIAMETER POLE FOOTING  
WITH MINIMUM EMBEDMENT = 5'-10"



ABBREVIATIONS

Table with 2 columns: TYP. and TYPICAL, VIF and VERIFY IN FIELD

GENERAL

- 1. THESE STRUCTURAL DRAWINGS AND SPECIFICATIONS, INCLUDING ANY ADDENDA... 2. THE PLANS REPRESENT ONLY THE FINISHED STRUCTURE... 3. IN USING THE PLANS FOR BIDDING OR CONSTRUCTION PURPOSES... 4. IN INTERPRETING THE PLANS, THE FOLLOWING GENERAL RULES APPLY... 5. IN IMPLEMENTING THE PLANS, THE FOLLOWING GENERAL RULES APPLY... 6. SUBMITTALS WILL BE REVIEWED BY THE STRUCTURAL ENGINEER... 7. IN NO EVENT WILL ANY SITE VISITS BY THE STRUCTURAL ENGINEER CONCERN... 8. COPIES OF THE PLANS PROVIDED IN ANY ELECTRONIC FORM ARE SUBJECT TO THE SAME PROVISIONS AS THE OTHER INSTRUMENTS OF SERVICE...

PROJECT DESIGN CRITERIA

- 1. WIND- ASCE 7-16, Vult = 96 MPH (EXPOSURE C); Vomb = 74 MPH (EXPOSURE C), RISK CATEGORY II 2. SEISMIC - SS=1.098; S1=0.392; SDS=0.776; SD1=0.522; RISK CATEGORY=I; I=1.0; SITE CLASS=D; R=1.5; SEISMIC DESIGN CATEGORY=D; 3. SEISMIC-FORCE-RESISTING-SYSTEM=NON-BUILDING STRUCTURE, NOT SIMILAR TO BUILDINGS; ANALYSIS PROCEDURE=EQUIVALENT LATERAL FORCE PROCEDURE. 4. MAX TENSION FORCE TO BE APPLIED TO POLE TYPE C1 DURING ERECTION OF CABLE NETTING SHALL BE = 378# 5. THESE FORCES CORRESPOND TO 1'-0" OF ANTICIPATED SAG ALONG THE CABLING.

EXISTING CONDITIONS

- 1. ALL INFORMATION SHOWN ON THE PLANS RELATIVE TO EXISTING CONDITIONS IS GIVEN AS THE BEST PRESENT KNOWLEDGE FROM PLANS SUPPLIED BY THE OWNER, BUT WITHOUT GUARANTEE OF ACCURACY. 2. WHERE ACTUAL CONDITIONS ARE NOT IN ACCORDANCE WITH THE INFORMATION PRESENTED, THE ARCHITECT SHALL BE NOTIFIED IMMEDIATELY. NO MODIFICATIONS OF THE PLANS FOR NEW CONSTRUCTION SHALL BE MADE WITHOUT THE WRITTEN APPROVAL OF THE ARCHITECT.

APPROVALS

- 1. THIS PROJECT IS EXEMPT FROM DSA STRUCTURAL REVIEW AND APPROVAL IN OWNER IS RESPONSIBLE FOR RETAINING DSA CERTIFIED INSPECTOR FOR ALL CONSTRUCTION ACCORDANCE WITH CCR, TITLE 24, PART 1, SECTION 4-308.

FOUNDATION

- 1. ALL PORTIONS OF WORK PERTAINING TO EXCAVATIONS, FOUNDATIONS AND RETAINING WALLS SHALL CONFORM TO TITLE 24, PART 2, CHAPTER 18A. 2. THE FOUNDATION DESIGN IS BASED ON MIN. CODE PRESCRIPTIVE VALUES TABLE 1806A.2. 3. THE CONTRACTOR SHALL PROVIDE FOR DE-WATERING OF EXCAVATIONS FROM EITHER SURFACE WATER, GROUND WATER OR SEEPAGE. 4. EXCAVATIONS FOR FOOTINGS SHALL BE APPROVED BY THE PROJECT INSPECTOR PRIOR TO PLACING CONCRETE AND REINFORCING. THE CONTRACTOR SHALL NOTIFY THE PROJECT INSPECTOR WHEN EXCAVATIONS ARE READY FOR INSPECTION. THE PROJECT INSPECTOR SHALL SUBMIT A LETTER OF COMPLIANCE TO THE OWNER. 5. ALL ABANDONED FOOTINGS, UTILITIES, ETC., THAT INTERFERE WITH NEW CONSTRUCTION, SHALL BE REMOVED. 6. THE CONTRACTOR SHALL IMMEDIATELY NOTIFY THE OWNER SHOULD ANY BURIED STRUCTURES, SUCH AS CESSPOOLS, CISTERNS, FOUNDATIONS, ETC., BE FOUND.

STRUCTURAL STEEL AND MISCELLANEOUS METAL

- 1. ALL PORTIONS OF WORK PERTAINING TO STRUCTURAL STEEL CONSTRUCTION SHALL CONFORM TO TITLE 24, PART 2, CHAPTER 22A. 2. ROUND HOLLOW STRUCTURAL SECTION (HSS) SHALL CONFORM TO ASTM A-500, GRADE B. 3. CHANNELS, ANGLES AND PLATES SHALL CONFORM TO ASTM A-36, UNLESS NOTED OTHERWISE. 7. ALL WELDING SHALL CONFORM TO THE STRUCTURAL WELDING CODE - STEEL, AWS D1.1 AND STRUCTURAL WELDING CODE SEISMIC SUPPLEMENT AWS D1.8, BY THE AMERICAN WELDING SOCIETY. WELDING RODS SHALL BE E70XX. 8. ALL WELDING SHALL BE PERFORMED BY CERTIFIED WELDERS. 9. ALL WELDS NOT SPECIFIED SHALL BE CONTINUOUS FILLET WELDS. SIZE OF WELDS SHALL BE BASED ON AWS D1.1 FOR THICKER PART JOINED. 10. DO NOT PAINT STRUCTURAL STEEL SURFACES THAT ARE TO BE ENCASED IN CONCRETE OR MASONRY. 11. ALL STRUCTURAL STEEL AND MISCELLANEOUS METAL ITEMS, INCLUDING CONNECTORS, EXPOSED TO THE WEATHER SHALL BE HOT-DIPPED GALVANIZED, AFTER FABRICATION. 12. STRUCTURAL STEEL SHALL BE DELIVERED TO THE JOB SITE FREE OF EXCESSIVE RUST, MILL SCALE, GREASE, ETC. 13. OPENINGS SHALL NOT BE PLACED IN STEEL MEMBERS UNLESS SPECIFICALLY DETAILED.

NETTING

- 1. NETTING CABLES, HARDWARE AND ATTACHMENTS IS BY OTHERS AND IS NOT A PART OF THIS SUBMITTAL.

CAISSONS

- 1. SEE FOUNDATION NOTES FOR ADDITIONAL INFORMATION. 2. CAISSON EXCAVATIONS SHALL BE APPROVED BY THE PROJECT INSPECTOR PRIOR TO PLACING CONCRETE AND REINFORCING. LENGTHS OF CAISSONS AS SHOWN ON DRAWINGS ARE ESTIMATED FROM AVAILABLE SOIL DATA. ACTUAL LENGTHS WILL BE DETERMINED BY THE GEOTECHNICAL ENGINEER. THE GEOTECHNICAL ENGINEER SHALL SUBMIT A LETTER OF COMPLIANCE TO THE OWNER. 3. DO NOT ALLOW SHAFTS TO REMAIN OPEN OVERNIGHT. FILL SHAFTS WITH CONCRETE IMMEDIATELY AFTER INSPECTION AND APPROVAL BY THE PROJECT INSPECTOR. 4. WHERE REQUIRED, PROVIDE FULL-LENGTH WATERTIGHT STEEL CASING OF SUFFICIENT THICKNESS TO WITHSTAND COMPRESSIVE DISPLACEMENT AND WITHDRAWAL STRESSES AND TO MAINTAIN SHAFT WALLS. TEMPORARY CASING SHALL BE WITHDRAWN AS CONCRETE IS PLACED. MAINTAIN A HEAD OF CONCRETE APPROXIMATELY 5 FEET ABOVE CASING BOTTOM. 5. KEEP EXCAVATIONS FREE OF WATER BEFORE PLACING CONCRETE. 6. REINFORCING CAGES IN SHAFTS ARE TO BE ONE CONTINUOUS UNIT. PLACE REINFORCEMENT ACCURATELY IN HOLE AND BRACE SECURELY IN POSITION DURING CONCRETE PLACEMENT. 7. USE PLYWOOD PROTECTION SHEETS WITH CUT OUTS TO RECEIVE CONCRETE AT EXCAVATION OPENINGS. EXTEND PLYWOOD AT LEAST 12" BEYOND EDGE. 8. USE ELEPHANT TRUNK, TREMIE, ETC., TO PLACE CONCRETE SO THAT FREE FALL DOES NOT EXCEED 5 FEET. PROVIDE MECHANICAL VIBRATION FOR FULL HEIGHT OF SHAFT TO CONSOLIDATE CONCRETE. PLACE CONCRETE IN EACH SHAFT IN ONE CONTINUOUS OPERATION. INTERRUPTED PLACING OPERATIONS OF OVER ONE-HOUR DURATION WILL REQUIRE A COLD JOINT INSTALLATION AND MUST BE APPROVED BY THE STRUCTURAL ENGINEER.

CONCRETE

- 1. ALL PORTIONS OF WORK PERTAINING TO CONCRETE CONSTRUCTION SHALL CONFORM TO TITLE 24, PART 2, CHAPTER 19A. 2. CONCRETE MIXES SHALL BE DESIGNED BY A QUALIFIED TESTING LABORATORY. MIX DESIGNS SHALL CONFORM TO ACI 318, SEC. 26.4, CBC SEC.1903A AND 1904A. MIX DESIGNS SHALL INCORPORATE THE FOLLOWING CRITERIA: - MINIMUM OF 5 SACKS OF CEMENT PER CUBIC YARD OF CONCRETE. MAXIMUM OF 7 SACKS OF CEMENT PER YARD OF CONCRETE. - MAXIMUM WATER/CEMENT RATIO (BY WEIGHT) OF CONCRETE IN CONTACT WITH SOIL SHALL BE 0.45. - MAXIMUM SLUMP SHALL NOT EXCEED 3" ± 1" FOR FOOTINGS, SLUMP LIMITATIONS NOTED SHALL APPLY TO CONCRETE MIX PRIOR TO THE ADDITION OF ANY WATER-REDUCING ADMIXTURES OR SUPER-PLASTICIZERS. MAXIMUM SLUMP MAY BE INCREASED TO 5 +/- 1" FOR MIX INCLUDING WATER-REDUCING ADMIXTURES OR SUPER-PLASTICIZERS. - CALCIUM CHLORIDE OR ADMIXTURES CONTAINING CHLORIDE(S) SHALL NOT BE USED. 3. SCHEDULE OF STRUCTURAL CONCRETE 28 DAY MINIMUM STRENGTHS AND TYPES: - FOOTINGS, CAISSONS, GRADE BEAMS 145 PCF, f'c = 4,500 PSI 4. PORTLAND CEMENT SHALL CONFORM TO ASTM C-150, TYPE II. CEMENT USED FOR CONCRETE IN CONTACT WITH SOIL SHALL CONFORM TO ASTM C-150, TYPE V. 5. AGGREGATE FOR NORMALWEIGHT CONCRETE SHALL CONFORM TO ASTM C-33. COMBINED AGGREGATE GRADATION OF 3/8" MAXIMUM (PEA GRAVEL) SHALL NOT BE USED. 6. READY MIXED CONCRETE SHALL CONFORM TO ASTM C-94. 7. ALL REINFORCING BARS, ANCHOR BOLTS AND OTHER CONCRETE INSERTS SHALL BE SECURED IN POSITION PRIOR TO PLACING CONCRETE. 8. THE FOLLOWING MINIMUM CONCRETE COVER SHALL BE PROVIDED FOR REINFORCEMENT: CONCRETE CAST AGAINST AND PERMANENTLY EXPOSED TO EARTH ..... 3"

KEY MAP

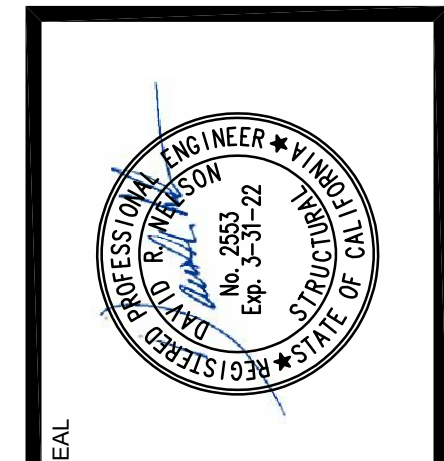
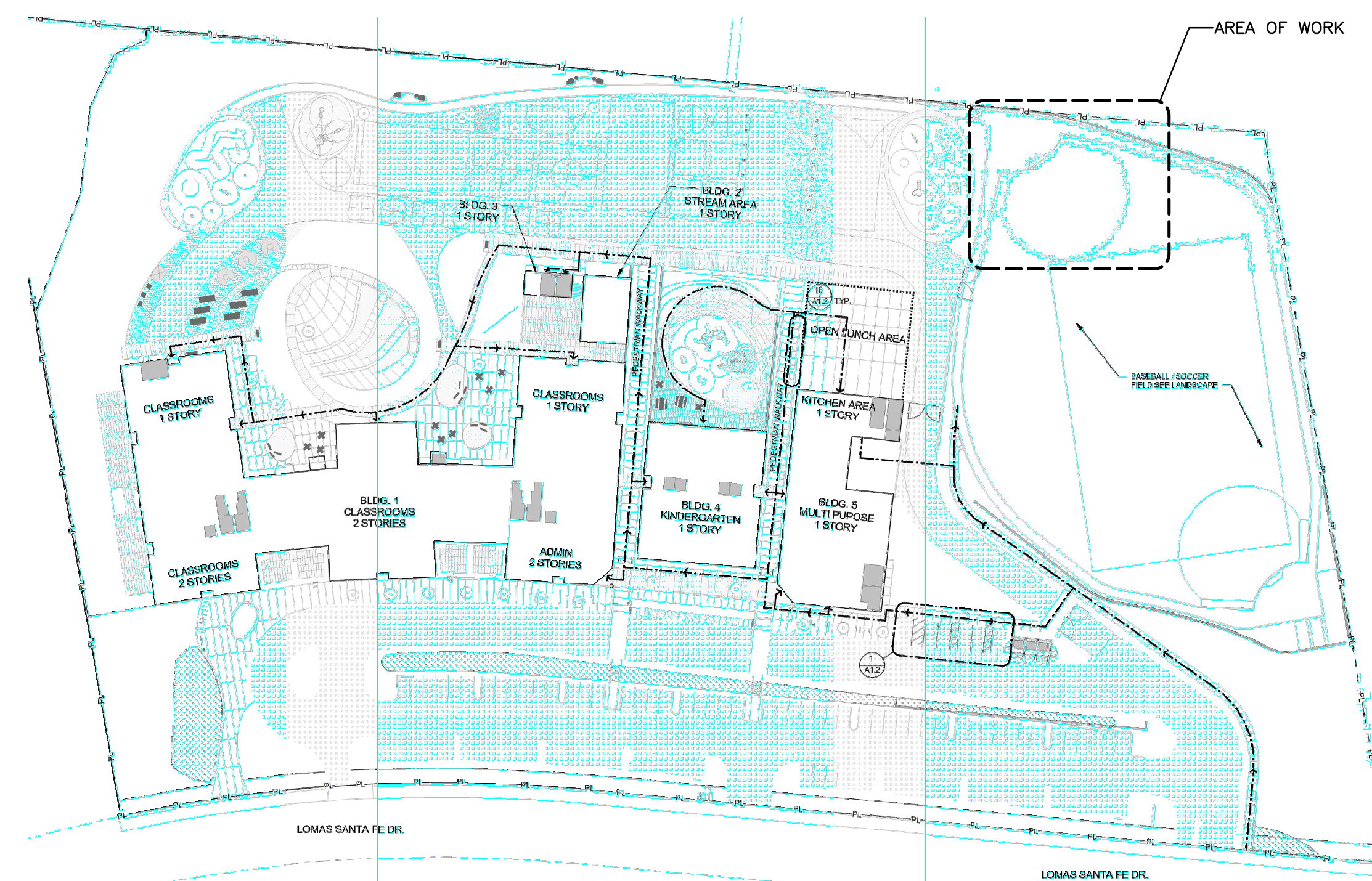

KNA STRUCTURAL ENGINEERS logo and contact information: 9991 Mulholland Boulevard, Irvine, CA 92618, Tel: (949) 462-9200, Fax: (949) 462-9201, KNA\_JOB\_NO.: 430.001

SKYLINE ELEMENTARY SCHOOL - BASEBALL NETTING  
606 LOMAS SANTA FE DR.  
SOLANA BEACH, CA 92705  
SOLANA BEACH SCHOOL DISTRICT  
GENERAL NOTES

Table with 2 columns: DATE (01/19/2021), KNA JOB NO. (430.001), DRAWN (NP), CHECKED (DN/RT)



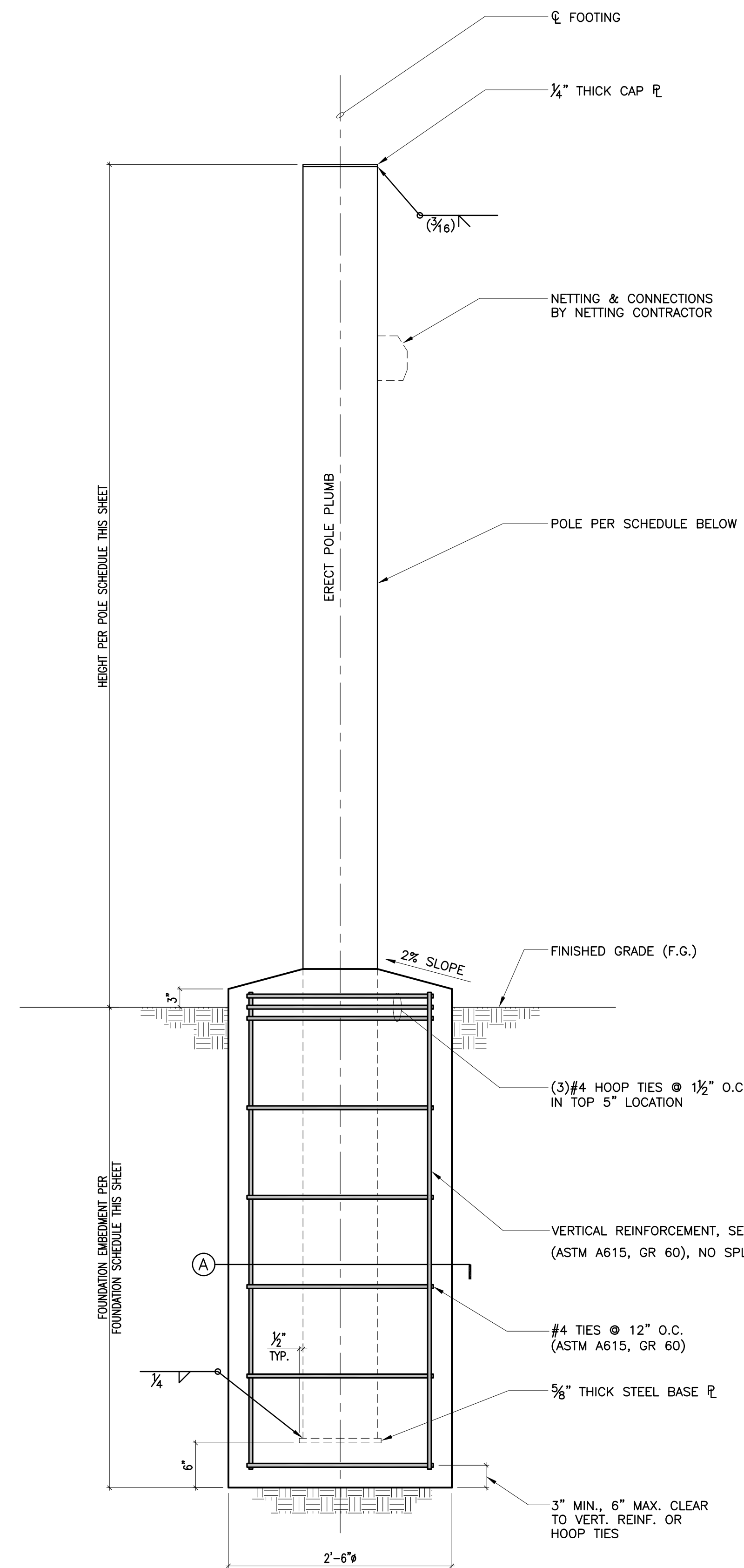

**POLE FOUNDATION DETAIL**

SCALE: NOT TO SCALE

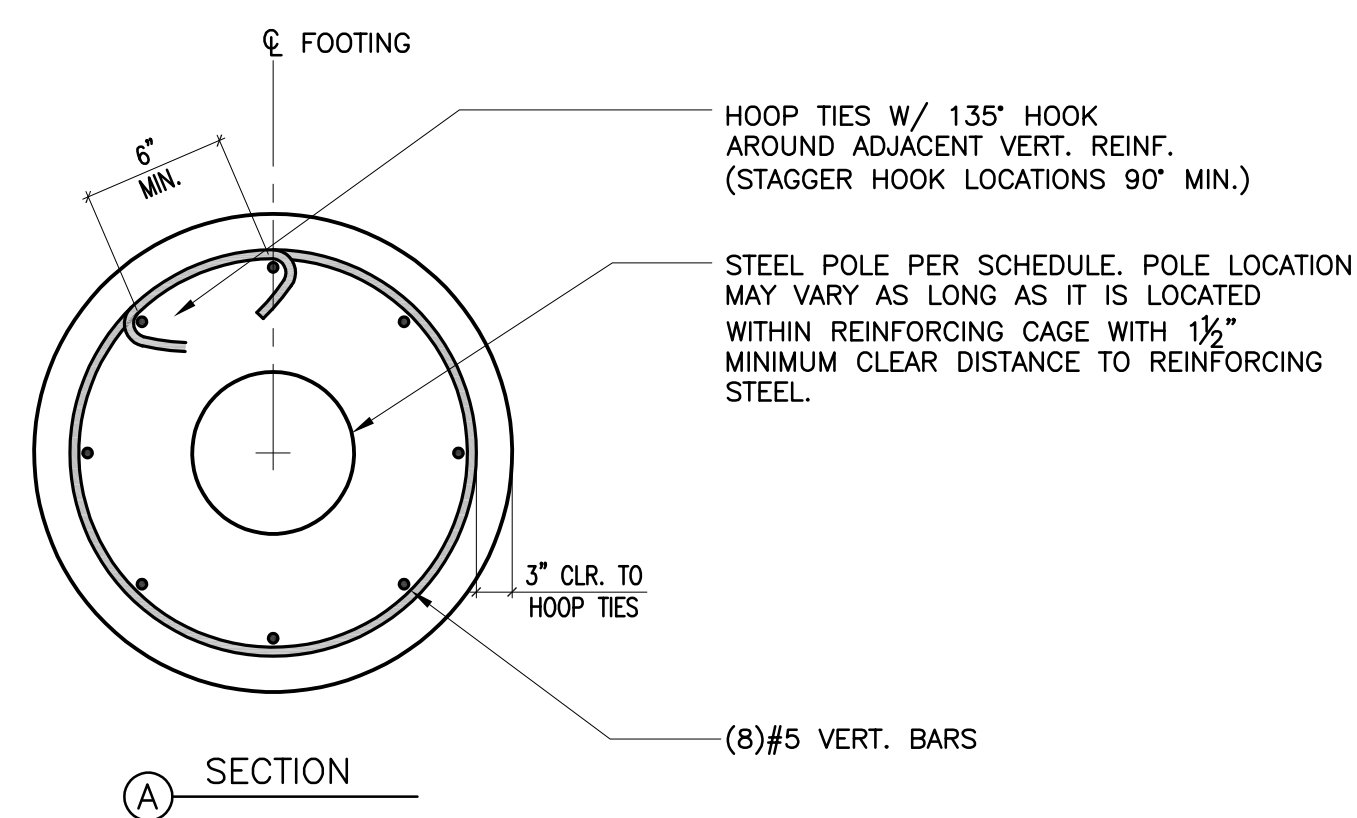

CASE	POLE SCHEDULE		POLE FOUNDATION SCHEDULE CONCRETE FOUNDATION		REMARKS
	TYPE	HEIGHT ABOVE GROUND	MIN. EMBEDMENT FROM F.G. (FEET)		
C1	10" PIPE X-STRONG (ASTM A53 GRADE B) OR HSS10.75x0.500 (A500 GRADE C)	22'-0"	11'-0"		ATTACH EXISTING CHAIN LINK FENCE TO "C1"
C2	8" PIPE STD. (ASTM A53 GRADE B) OR HSS 8.625x0.322 (A500 GRADE C)	16'-0"	8'-0"		

**LEGEND**

- : INDICATES EXISTING POLE IN CHAIN LINK FENCE.
- : INDICATES NEW POLE TO SUPPORT NETTING.
- : EXISTING CHAIN LINK FENCE.

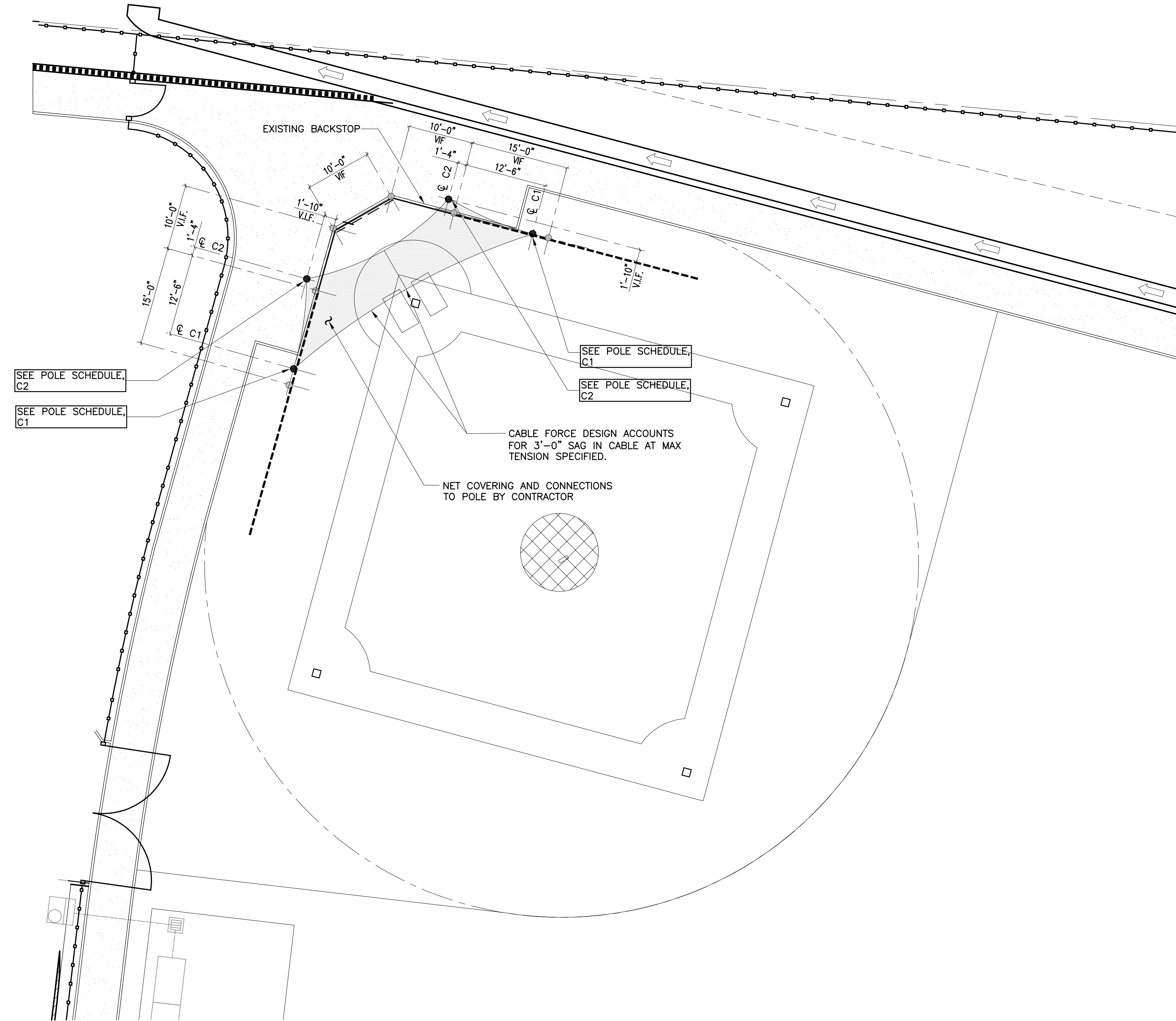

**PARTIAL SITE PLAN**

SCALE: 3/32"=1'-0"

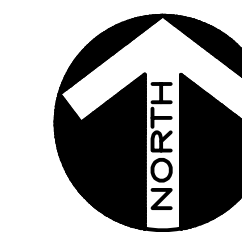

NOTE:  
THIS DRAWING IS EXEMPTED FROM DSA SSS REVIEW PER:  
• CRC TITLE 24, PART I, SECTION 4-314 DEFINITION OF "SCHOOL BUILDING"  
• DSA IR A-22 APPENDIX ITEM 11.

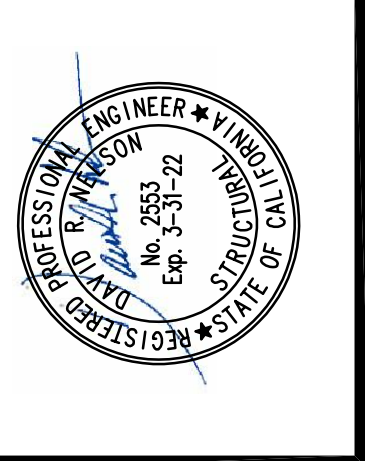

**KNA STRUCTURAL ENGINEERS**  
9991 Mulholland Boulevard, Irvine, CA 92618  
Tel: (949) 462-3200, Fax: (949) 462-3201  
KNA JOB NO. 430.001

SKYLINE ELEMENTARY SCHOOL - BASEBALL NETTING  
606 LOMAS SANTA FE DR.  
SOLANA BEACH, CA 92705  
SOLANA BEACH SCHOOL DISTRICT  
PARTIAL SITE PLAN, AND DETAILS

DATE	01/19/2021
KNA JOB NO.	430.001
DRAWN	NP
CHECKED	DN/RT

SHEET 2 OF 2